

SCAG[®]

POWER EQUIPMENT

MODEL STHM



THIS MANUAL CONTAINS THE OPERATING INSTRUCTIONS AND SAFETY INFORMATION FOR YOUR SCAG MOWER. READING THIS MANUAL CAN PROVIDE YOU WITH ASSISTANCE IN MAINTENANCE AND ADJUSTMENT PROCEDURES TO KEEP YOUR MOWER PERFORMING TO MAXIMUM EFFICIENCY. THE SPECIFIC MODELS THAT THIS BOOK COVERS ARE CONTAINED ON THE INSIDE COVER. BEFORE OPERATING YOUR MACHINE, PLEASE READ ALL THE INFORMATION ENCLOSED.

OPERATOR'S MANUAL



WARNING:

FAILURE TO FOLLOW SAFE OPERATING PRACTICES MAY RESULT IN SERIOUS INJURY.

- * Keep all shields in place, especially the grass discharge chute.
- * Before performing any maintenance or service, stop the machine and remove the spark plug wire and ignition key.
- * If a mechanism becomes clogged, stop the engine before cleaning.
- * Keep hands, feet and clothing away from power-driven parts.
- * Read this manual completely as well as other manuals that came with your mower.
- * Keep others off the tractor (only one person at a time)

REMEMBER - YOUR MOWER IS ONLY AS SAFE AS THE OPERATOR!

Hazard control and accident prevention are dependent upon the awareness, concern, prudence, and proper training of the personnel involved in the operation, transport, maintenance, and storage of the equipment.

This manual covers the operating instructions
and illustrated parts list for:

STHM-23CV with a serial number of **B3600001 to B3699999**
SM-61V with a serial number of **B3700001 to B3799999**
SM-72A with a serial number of **B3800001 to B3899999**

Always use the entire serial number listed on the serial number tag when referring to this product.

SCAG[®]

POWER EQUIPMENT

TABLE OF CONTENTS

MODEL STHM

SUBJECT	PAGE
Introduction	1
General Safety Instructions	1
Signal Words	1
Symbols	2-3
Before Operating	4
While Operating	5-6
Maintenance and Storage	6-7
Initial Run-In Procedures	7
Mower Operation	8-9
Parking Brake Adjustments	9
Neutral Adjustment	9-10
Belt Tension	10-11
Belt Alignment	11
Cutter Deck Adjustments	11-12
Cutter Blades	13
Custom-Cut Baffle Adjustment	13-14
Lubrication and Maintenance	15
Troubleshooting Cutting Conditions	16-18
Technical Specifications	19-20
Notes	21



TABLE OF CONTENTS

(CONTINUED)

SUBJECT	PAGE
Illustrated Parts List	
SM 61V, 72A Cutter Deck.....	22-23
Engine Deck	24-25
Upper Hydraulics	26-27
Lower Hydraulics.....	28-29
Control Linkage.....	30-31
Instrument Panel	32-33
Rider Frame Assembly	34-35
Brake Linkage	36-37
Electrical System	38
Winch Lift System	39
Replacement Decals	40
Warranty Statement.....	following section 8

INTRODUCTION

Your mower was built to the highest standards in the industry. However, the prolonged life and maximum efficiency of your mower depends on you following the operating, maintenance and adjustment instructions in this manual.

We encourage you to contact your dealer for repairs. All Scag dealers are informed of the latest methods to service this equipment and provide prompt and efficient service in the field or at their service shop. They carry a full line of Scag service parts.

A replacement Operator's Manual is available from your Scag Servicing Dealer or by contacting Scag Power Equipment, Service Department at P.O. Box 152, Mayville, WI 53050 or contact us via the Internet at www.scag.com. The manual for this machine can be downloaded by using the model and serial number or use the contact form to make your request.

USE OF OTHER THAN ORIGINAL SCAG REPLACEMENT PARTS WILL VOID THE WARRANTY.

The “Right” and “Left”, “Front” and “Rear” of the machine are referenced from the operator’s perspective when in the normal operating position and facing the forward travel direction.

GENERAL SAFETY INSTRUCTIONS

READ THIS OPERATOR'S MANUAL and all instructions furnished with attachments.

Perform only those maintenance procedures described in this manual. If major repairs are ever needed or assistance is desired, contact an Authorized Scag Dealer. To ensure optimum performance and safety, always purchase genuine SCAG replacement parts and accessories.

Your safety and the safety of others depends significantly upon your knowledge and understanding of all correct operating practices and procedures of this machine.

SIGNAL WORDS



This symbol means “**Attention! Become Alert! Your Safety is Involved!**”. The symbol is used with the following signal words to attract your attention to safety messages found on the decals and throughout this manual. The message that follows the symbol contains important information about safety. To avoid injury and possible death, carefully read the message! Be sure to fully understand the causes of possible injury or death.

Signal Word:

It is a distinctive word on safety decals and throughout this manual that alerts the viewer to the existence and relative degree of the hazard.



The signal word “DANGER” denotes that an extremely hazardous situation exists on or near the machine that could result in high probability of death or irreparable injury if proper precautions are not taken.























The signal word “WARNING” denotes that a hazard exists on or near the machine that can result in injury or death if proper precautions are not taken.



The signal word “CAUTION” is a reminder of safety practices on or near the machine that could result in personal injury if proper precautions are not taken.

ISO Symbols		CE Mark
-------------	---	---------

SYMBOL	DESCRIPTION	SYMBOL	DESCRIPTION
	Choke		Transmission
	Parking Brake	 <small>48071S</small>	Spinning Blade
	On/Start		Spring Tension on Idler
	Off/Stop		Oil
	Falling Hazard		Thown Object Hazard

SYMBOL	DESCRIPTION	SYMBOL	DESCRIPTION
	Fast		Slow
	Continuously Variable - Linear		Cutting Element - Basic Symbol
	Pinch Point		Cutting Element - Engage
	Hourmeter/Elapsed Operating Hours		Cutting Element - Disengage
	Thown Object Hazard Keep Bystanders Away		Read Operator's Manual



BEFORE OPERATING

1. **NEVER** allow children to operate this riding mower. Do not allow adults to operate this machine without proper instructions.
2. **DO NOT** mow when children and/or others are present. Keep children out of the mowing area and in the watchful care of a responsible adult other than the operator. Be alert and turn machine off if a child enters the area.
3. The owner/user can prevent and is responsible for accidents or injuries occurring to themselves, other people or property.
4. Clear the area to be mowed of objects that could be picked up and thrown by the cutter blades.
5. **DO NOT** carry passengers.
6. **DO NOT** operate the machine under the influence of alcohol or drugs.
7. Fill the fuel tank with clean, fresh gasoline, with a minimum octane rating of 87. To avoid personal injury or property damage, use extreme care in handling gasoline. Gasoline is extremely flammable and the vapors are explosive.
 - A. Extinguish all cigarettes, cigars, pipes and other sources of ignition.
 - B. Use only an approved gasoline container.
 - C. Never remove the gas cap or add fuel with the engine running. Allow the engine to cool before fueling.
 - D. Never fuel the machine indoors or in an enclosed trailer.
 - E. Never store the machine or fuel container where there is an open flame, spark or pilot light such as on a water heater or other appliances.
 - F. Never fill containers inside a vehicle or on a truck or trailer bed with a plastic liner. Always place containers on the ground away from your vehicle before filling.
 - G. Remove the machine from the truck or trailer and fuel on the ground. If this is not possible, then refuel the machine with a portable container, rather than from a gasoline dispenser nozzle.
 - H. Keep the nozzle in contact with the rim of fuel tank or container opening at all times until fueling is complete. Do not use a nozzle lock-open device.
 - I. If fuel is spilled on clothing, change clothing immediately.
 - J. Replace gas cap and tighten securely.
8. If the operator(s) or mechanic(s) cannot read English or Spanish, it is the owner's responsibility to explain this material to them.
9. **DO NOT** wear loose fitting clothing that could get tangled in moving parts. Do not operate the machine wearing shorts; always wear adequate protective clothing including long pants. Wearing safety glasses, safety shoes and a helmet is advisable and is required by some local ordinances and insurance regulations.
10. Operator hearing protection is recommended, particularly for continuous operation of the mower. Wear suitable hearing protection. Prolonged exposure to loud noise can cause hearing impairment or loss.
11. Keep the machine and attachments in good operating condition. Keep all shields and safety devices in place. If a shield, safety device or decal is defective or damaged, repair or replace it before operating the machine.
12. Be sure the safety switches are functioning correctly.
13. **USE ONLY SCAG APPROVED ATTACHMENTS AND ACCESSORIES.** Attachments and accessories manufactured by companies other than Scag Power Equipment are not approved for use on this machine. Scag approved attachments and accessories:
 - Mulch Plate (p/n 9288, 9262)
 - Hurricane Mulch (p/n 9285, 9267)
 - Cup Holder (p/n 9240)

WHILE OPERATING

1. Start the engine when the cutter blades are disengaged, the parking brake is on and the right foot pedal is in the neutral position. Only start the engine from the operators position.
2. Do not run the engine in a confined area without adequate ventilation. Exhaust fumes are hazardous and could possibly be deadly.
3. Use care when loading or unloading the machine onto a trailer or truck.
4. Look behind and down before backing up to be sure of a clear path.
5. Using the machine demands attention. To prevent loss of control:
 - A. Mow only in daylight or when there is good artificial light.
 - B. Watch for holes or other hidden hazards.
 - C. Do not drive close to a drop-off, ditch, creek bank, or other hazard.
 - E. Do not operate where conditions are slippery.
6. The discharge chute must always be installed and in the down position on the side discharge cutter deck except when the mulching plate or Hurricane Mulch Kit are properly installed. If the discharge area should plug, shut the engine off and wait for all movement to stop before removing the obstruction.
7. **NEVER** operate with the PTO shield, or other guards not securely in place. Be sure all interlocks are attached, adjusted and functioning properly.
8. Disengage the blades and wait for them to stop before crossing gravel drives, walks or roads.
9. Be aware of discharge direction and do not point at anyone.
10. Keep hands and feet away from cutting units.
11. Shut the engine off and wait until the blades come to a complete stop before removing the grass catcher container.
12. Never raise the cutter deck while the blades are rotating.
13. Always park the mower and/or start the engine on a level surface. Apply the parking brake to prevent the mower from moving when you are not in the operator's position.
14. If the cutting blades should strike a solid object or the equipment should start to vibrate abnormally, stop the engine, disconnect the spark plug wires, and check immediately for the cause. Vibration is generally a warning of trouble. Check the machine for damaged or defective parts. Repair any damage before starting the engine or operating the cutter deck. Be sure the blades are in good condition and the blade bolts are tight.
15. Reduce speed and exercise extreme caution on slopes and in sharp turns to prevent tipping or loss of control. Be especially cautious when changing directions on slopes.
16. Use care when approaching blind corners, shrubs, trees, or other objects that may obscure vision.
17. Do not touch the engine or muffler while the engine is running or soon after it is stopped. These areas could be hot enough to cause a burn.

WARNING:

DO NOT operate on steep slopes. To check a slope, attempt to back up it (with the cutter deck down). If the machine can back up the slope without the wheels slipping, reduce speed and use extreme caution. ALWAYS FOLLOW OSHA APPROVED OPERATION.

18. Before leaving the operator's position or leaving the mower unattended, move the right foot pedal into the neutral position, apply the parking brake, and move the blade engagement switch to OFF. Shut the engine OFF and remove the key.
19. Do not pass or stand on the grass discharge side of any mower with the engine running. Stop the cutter blades when another person approaches.



WARNING:

Battery posts, terminals, and related accessories contain lead and lead compounds, chemicals known to the State of California to cause cancer and reproductive harm. Wash hands after handling.

7. Be sure the machine is in safe operating condition by keeping nuts, bolts, and screws tight. Check the blade mounting bolts and nuts frequently to be sure they are tightened.
8. If the engine must be running to perform a maintenance adjustment, keep hands, feet, clothing and other parts of the body away from the cutter deck blades and other moving parts.
9. Do not overspeed the engine by changing governor settings. To be sure of safety and accuracy, have an authorized dealer check maximum engine speed with a tachometer.
10. The engine must be shut off before checking the oil or adding oil to the crankcase.

MAINTENANCE AND STORAGE

1. Disconnect the spark plug wire from the spark plug to prevent accidental starting of the engine when servicing, adjusting or storing the machine.
2. If the mower must be tipped to perform maintenance or adjustment, remove the battery, drain the gasoline from the fuel tank and the oil from the crankcase. Use jack stands to support the machine when required.
3. To reduce potential fire hazard, keep the engine free of excessive grease, grass, leaves and accumulations of dirt.
4. Park the machine on level ground. Never allow untrained personnel to service the machine.
5. Disconnect battery or remove spark plug wires before making any repairs. Disconnect the negative terminal first and the positive last. Reconnect positive first and negative last.
6. Use care when checking blades. Wrap the blades or wear gloves and use caution when servicing them. Only replace blades. Never straighten or weld them.
7. Allow the engine to cool before storing the mower in any enclosure such as a garage or storage shed. Make sure the fuel tank is empty if the machine is to be stored in excess of 30 days. Do not store the mower near any open flame or where gasoline fumes may be ignited by a spark.
8. Always store gasoline in a safety-approved, red container.
9. Be careful when servicing the battery as it contains acid, which is corrosive and could cause burns to skin and clothing.
10. Batteries release explosive gases when being charged or discharged. Keep batteries away from any source of sparks and/or flame. Charge batteries in an open, well ventilated area.
11. Make sure all hydraulic connections are tight and all hydraulic hoses and lines are in good condition before starting the machine.

 **WARNING:**

Hydraulic fluid is under high pressure. Keep body and hands away from pinholes or nozzles that eject hydraulic fluid under high pressure. If you need service on your hydraulic system, please see your authorized Scag dealer. If hydraulic fluid is injected into the skin, it must be surgically removed within a few hours by a doctor or gangrene may result.

INITIAL RUN-IN PROCEDURES (FIRST DAY OF USE OR APPROXIMATELY 10 HOURS)

1. Check the belts for proper tension at 2, 4 and 8 hours. Adjust as needed. (See Belt Tension, page 9).
2. Check the neutral adjustment. (See Adjustments, page 8)
3. Check the tires for proper pressure.

Caster Wheels	Flat Free
Drive Wheels	12 psi
Rear Steering Wheel	15 psi
4. Check for loose hardware. Tighten as needed.
5. Check the safety switches for proper adjustment:
 - * The engine should crank and start if the machine is in neutral, the PTO engagement switch is OFF and the parking brake is ON.
7. Apply lubricant to all the grease fittings. Lubricant was applied at the factory. This is just a precautionary check to make sure that all the fittings have been lubricated.

MOWER OPERATION

1. Read and understand the safety instructions before attempting to operate this machine.
2. Before starting the engine:
 - * Check the oil level in the engine and the hydraulic reservoir.
 - * Fill the fuel tank with clean, fresh, lead-free gasoline.
 - * Open the fuel valve on the bottom of the fuel tank.

-NOTE-

Use gasoline with an octane rating no less than 87.

- * The right hand foot pedal must be in the NEUTRAL position.
 - * The blade clutch switch must be in the OFF position.
 - * The parking brake must be ON.
3. Start the engine:
 - * Choke as required. If the engine is cold, pull the choke knob out. When the engine starts, slowly push the choke in. If the engine stalls, repeat the above operation. When the engine is warm, choking may not be necessary.
 4. Depress the left hand operator presence pedal.
 5. Engage the cutter blades by pulling the blade clutch switch into the ON position. Push the switch to the OFF position to disengage the cutter blades.

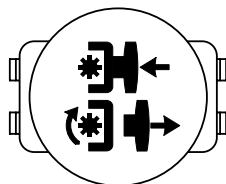
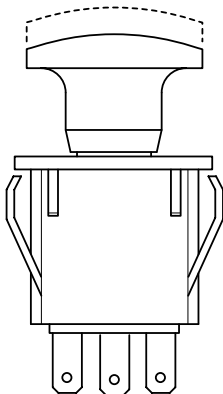

PULL UP TO ENGAGE

PUSH DOWN TO DISENGAGE

390S0138

-NOTE-

When the PTO is engaged or (possibly) disengaged, a squealing sound from the underside of the machine is normal. It is caused by the electric clutch plates meshing as the cutter blades come up to speed. For best equipment life, engage the clutch with the engine at 3/4 throttle, not under full load.

WARNING:

If you are not familiar with the operation of the hydrostatic drive, practice turning and maneuvering before engaging the cutter blades.

5. Release the parking brake. Depress the right foot pedal at the toe end to drive forward (See Figure 1) or depress the pedal at the heel end to drive in reverse. (See Figure 2)

-NOTE-

The left side operator presence pedal must be depressed for operation.

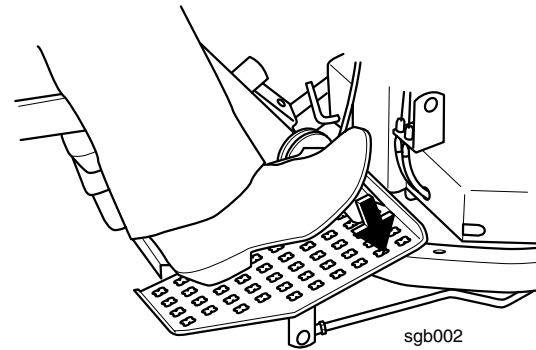

Depress Toe End of Pedal
Figure 1. Forward Operation

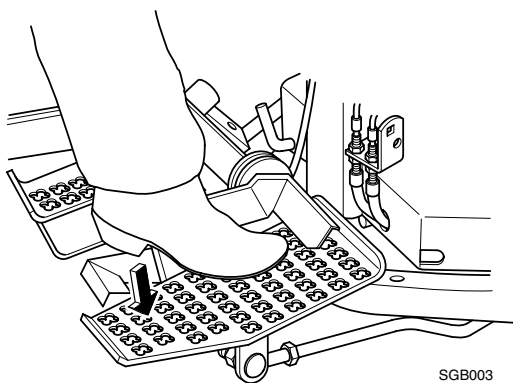

Depress Heel End of Pedal

Figure 2. Reverse Operation

6. When driving over curbs, disengage the cutter blades and raise the cutter deck to clear the curb. Drive forward over the curb. After the curb is clear, lower the cutter deck back to normal operating position. Be sure to leave slack in the cable after lowering the cutter deck.
7. To "freewheel" or move the machine around without the engine running, rotate the dump valve lever located on the left rear of the engine deck to the freewheel position (See Figure 3). The lever must be returned to the drive position to operate the machine.

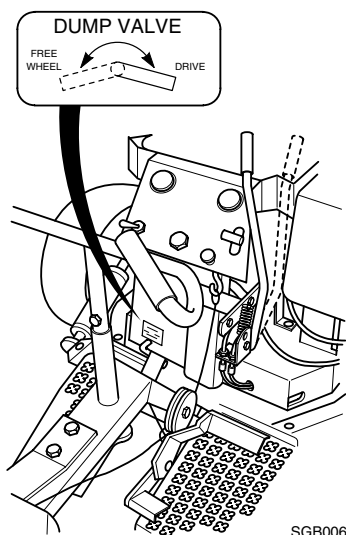

Figure 3. Dump Valve Location

-NOTE-

To prevent damage to the hydraulic system, do not exceed 1MPH when moving the machine in the freewheel position.

ADJUSTMENTS

PARKING BRAKE

Minor brake adjustments can be made by loosening the top nut on both brake cables (see Figure 4). Back the nuts off approximately 1/4". While pulling one cable downward, tighten the bottom nut on the cable until it touches the bottom of the brake cable mount. Tighten both the top and bottom nuts to lock the cable in place. Repeat the above steps for the second brake cable. Make sure that both cables are adjusted evenly so that the brakes do not cause the mower to pull to the left or right.

-NOTE-

This is a minor brake adjustment. If the brakes do not function properly after this adjustment, see your Scag Service Dealer before operating your mower.

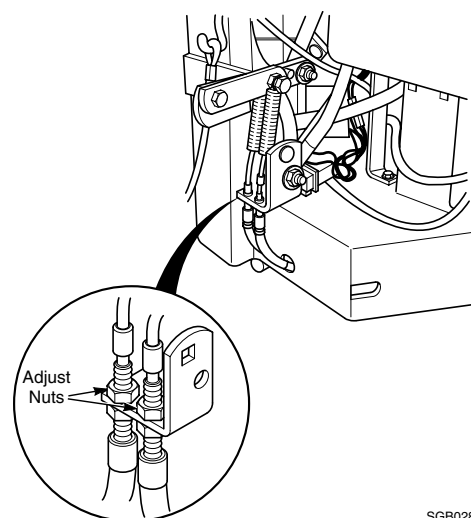

Figure 4. Parking Brake Adjustment

NEUTRAL ADJUSTMENT

1. Set the engine deck up on jack stands so the wheels are free to rotate.
2. Block the caster wheels to prevent an accident should the machine fall off the jack stands.
3. Start the engine and determine if the drive wheels rotate.

If the drive wheels consistently rotate when foot pedal control is in neutral, go to step 4.

If the drive wheels inconsistently rotate, i.e. drive wheels sometimes rotate and sometimes do not when foot pedal is not depressed, then check neutral adjustment bolt for "zero free play" in neutral control spring.

-NOTE-

If there is free play in the foot pedal have your SCAG servicing dealer inspect the machine and repair it as needed.

4. If the drive wheels rotate in the forward travel direction, turn the adjustment bolt clockwise until the tire rotation stops. If the drive wheels rotate in the backward travel direction, turn the adjustment bolt counter-clockwise until the tire rotation stops (See Figure 5).

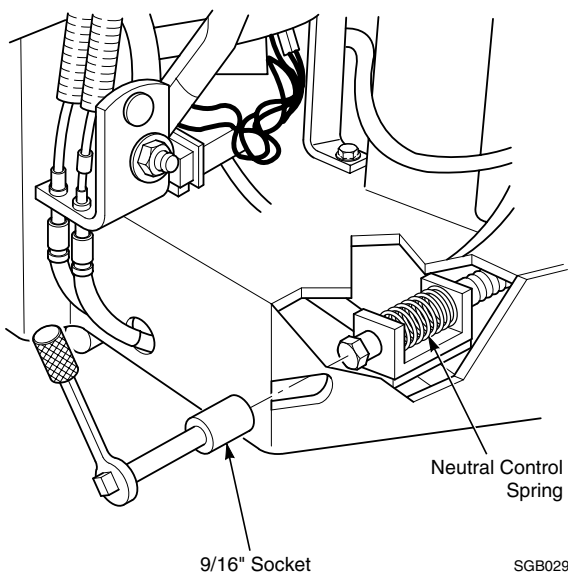

Figure 5. Neutral Adjustment

5. Check the adjustment of the right foot control pedal for full forward speed. The pedal should rest on the foot plate when the pump is stroked in the full forward position. To make an adjustment, disconnect the ball joint from the pedal arm and loosen the jam nut (See Figure 6). Place the foot control pedal forward against the foot rest and adjust the ball joint on the rod until the stud aligns with the hole in the arm. Bolt the ball joint to the arm and tighten the jam nut.

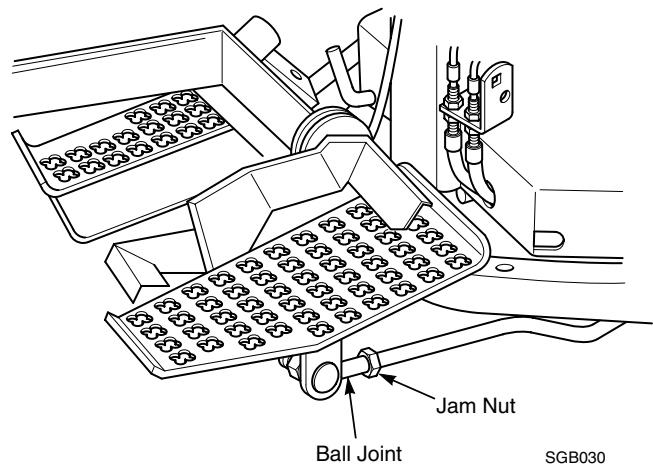

Figure 6. Foot Control Pedal Adjustment

6. Start the engine. The wheels should rotate only when the foot control pedal is depressed.

BELT TENSION

⚠ CAUTION:

Stop engine and remove the key from the ignition before making any adjustments. Wait for all moving parts to come to a complete stop before beginning work.

-NOTE-

The Hydro Drive Belt is spring-loaded and does not require adjustment.

To adjust cutter deck drive and blade belts:

1. Remove belt cover.

- To adjust cutter deck drive belt: Adjust the nut so that the belt moves 1/2" with 10 pounds of pressure. (See Figure 7).

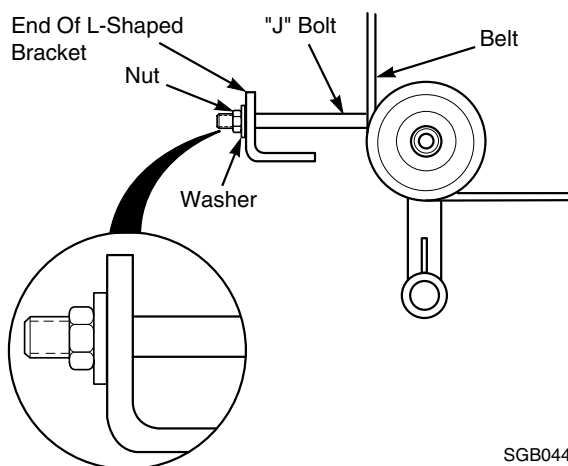

SGB044

Figure 7. Cutter Deck Drive Belt Tension

- To adjust blade drive belt: Using a belt tension gauge, check the belt tension so that the belt moves 1/2" with 10 pounds of pressure. (See Figure 8).

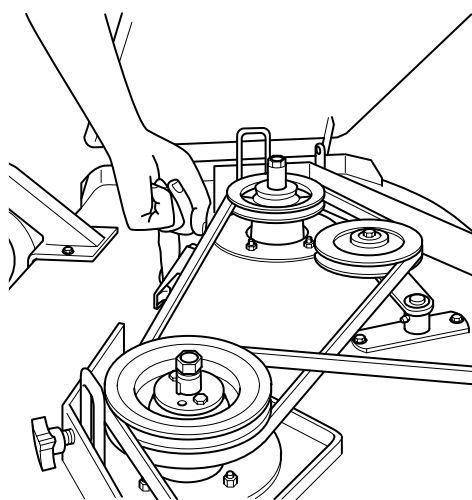

Use of Tension Gauge

sgb007

Figure 8. Blade Drive Belt Tension Check

Adjust the tension by tightening or loosening the nut on the J-bolt. (See Figure 9).

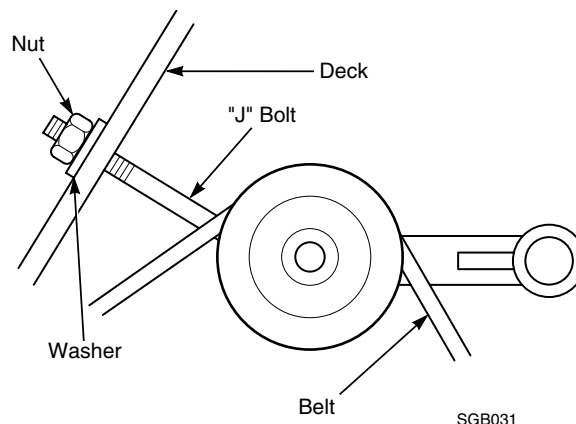

SGB031

Figure 9. Blade Belt Tension Adjustment

- Replace the belt covers.

BELT ALIGNMENT

Belt alignment is important for proper performance of your Scag mower. If you experience frequent belt wear or breakage, see your authorized Scag Service Dealer for belt adjustment.

CUTTER DECK ADJUSTMENTS

Due to the many conditions that exist, it is difficult to suggest a setting that will work for every lawn. There are, however, two adjustments that should be made on the cutter deck: pitch and height.

PITCH is the angle of the blades (comparing front to rear).

HEIGHT is the nominal distance that the blade is off the ground. This measurement is made with the blades pointed side to side and distance is measured between cutting tip and ground.

Adjusting the blade height can be done by moving any number of the five smaller spacers on the blade mounting bolts to the top or to the bottom of the spindle shaft. All blades should be positioned equally (See Figure 10).

The unit is shipped with one spacer on top of spindle and four underneath (See Figure 10).

This adjustment does not affect blade pitch.

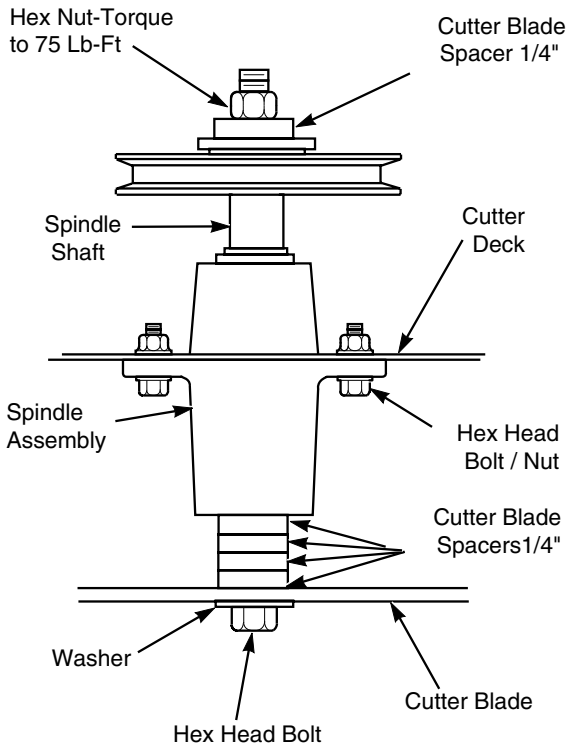

Figure 10. Cutter Blade Adjustment

-NOTE-

For best results, keep the cutter deck high in relation to the engine deck and the blades low in the cutter deck; ie. 4 or 5 spacers below the spindle shaft.

Additional range to the cutting height can be achieved by repositioning the cutter deck in relationship to the engine deck. This adjustment also affects the pitch of the deck.

There are three positions for mounting the cutter deck (See Figure 11). For cutting in the lowest position, mount the cutter deck in the top hole (A). For cutting in the highest position, mount the deck in the lowest hole (C). Setting the cutter deck height will be determined by the type of cutting conditions.

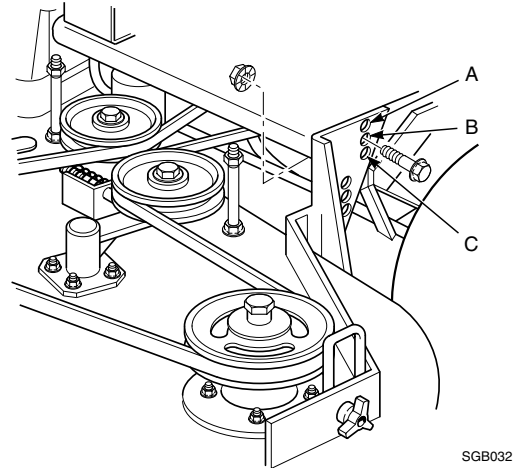

Figure 11. Cutter Deck Height Adjustment

Caster spacers also can be repositioned to change the cutting heights and to change the pitch of the deck (See Figure 12).

To adjust the caster spacers, raise the deck and remove the pin and caster wheel. Reposition the caster spacers as needed, then replace the caster, top spacers and pin. Make the same adjustments on the other caster wheel.

To adjust the blade height, move any number of the five 1/4" thick spacers on the blade mounting bolts to the top of the spindle shaft or below the spindle shaft.

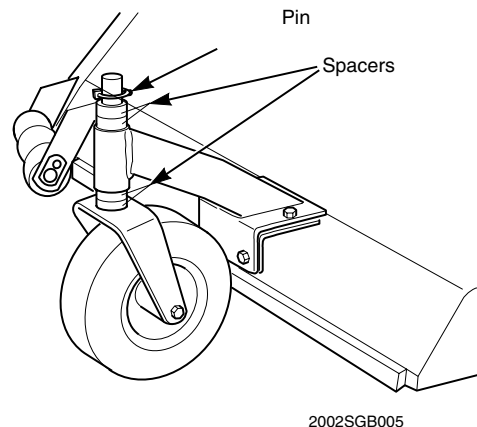

Figure 12. Repositioning Spacers

CUTTER BLADES

! CAUTION:

Blades have a sharp cutting edge. Wear protective gloves or wrap blades with protective material when removing, sharpening and installing blades.

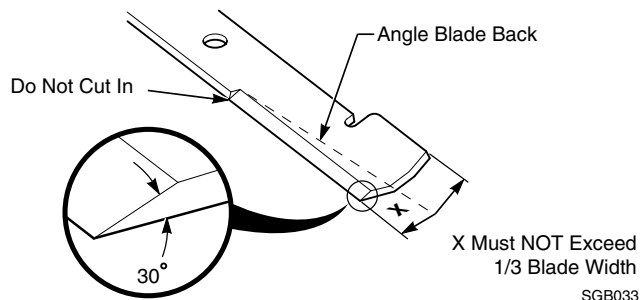

Figure 13. Blade Sharpening

Do not sharpen beyond 1/3 of the width of the blade. (See Figure 13).

-NOTE-

Dress the blade with a file. Using a wheel grinder may burn the blade. Check the balance of the blade. If blades are out of balance, vibration and premature wear can occur. See your authorized Scag Dealer for blade balance tools.

CUSTOM-CUT BAFFLE ADJUSTMENT

The Custom-Cut Baffle is designed to deliver optimum airflow and superior cutting performance in any type of grass. The Custom-Cut Baffle can be raised or lowered to precisely tailor the deck's performance for the type of grass being cut. The baffle can be set in three (3) different positions for optimum performance.

- A. 3" Position - baffle is installed using the top set of holes on the front baffle welded inside the cutter deck. (See Figure 15). The Advantage cutter deck will deliver the best quality-of-cut in very tall, wiry, tough to cut grass.
- B. 3-1/2" Position (factory setting, Advantage Deck) - baffle is installed using the middle set of holes on the front baffle welded inside the cutter deck. (See Figure 16). For general purpose cutting, place the Custom-Cut Baffle in the 3-1/2" position. This gives the best mix of cutting performance in all types of grass.
- C. 4" Position (factory setting, Velocity Plus Deck) - baffle is installed using the bottom set of holes on the front baffle welded inside the cutter deck. (See Figure 17). Placing the baffle in the 4" setting will enhance fall cutting (leaf pickup) and reduce cutter deck "blowout".

To adjust the Custom-Cut Baffle height:

1. Place the cutter deck in the transport position.
2. Remove the hardware securing the Custom-Cut Baffle to the cutter deck. (See Figure 14).

-NOTE-

Hardware location used in the illustrations are for reference only. Location of hardware may vary depending on cutter deck size.

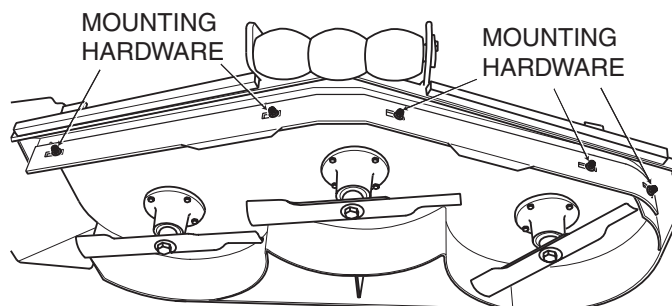

Figure 14. Custom-Cut Baffle

3. Move the Custom-Cut Baffle to desired position.
(See Figures 15 through 17 for position).
4. Reinstall the mounting hardware as shown. (See Figures 15 through 17). Torque hardware to 39ft.lbs.

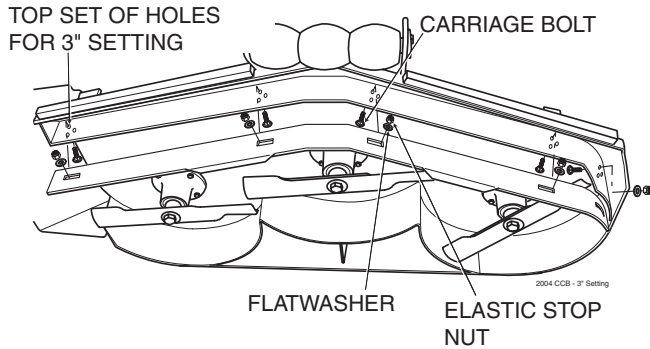

Figure 15. 3" Custom-Cut Baffle Position

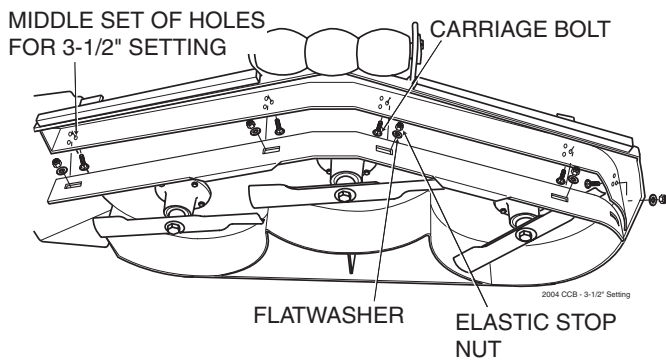

Figure 16. 3-1/2" Custom-Cut Baffle Position

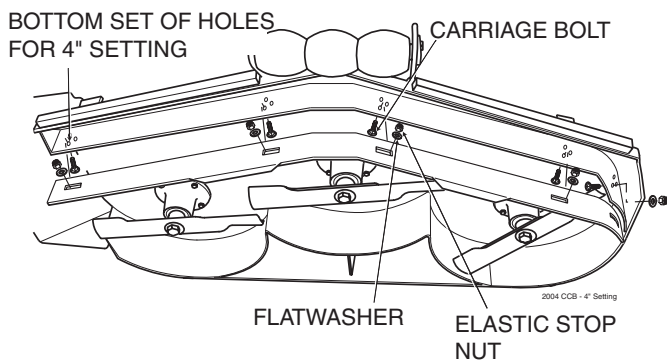

Figure 17. 4" Custom-Cut Baffle Position

LUBRICATION & MAINTENANCE

* Lubrication may be required every 8 to 40 hours, depending on climate and environment.

+ Compatible Greases: Mobilux #2 found at Mobil Service Stations
 Ronex MP found at Exxon Service Stations
 Super Lube MEP #2 & Super Stay-M #2 found at Conoco Service Stations
 Shell Alvania #2 found at Shell Service Stations
 Lidok EP #2 found at industrial shops

	Break-In (1st 10 Hours)	8 Hours (Daily)	25 Hours	40 Hours (Weekly)	100 Hours (Biweekly)	200 Hours (Monthly)	500 Hours or Annually	PROCEDURE	COMMENTS
X X X X								Check all hardware for proper tightness Change engine oil and filter at 5 hours Check hydrostatic oil level Check belt tension	Add oil as needed - SAE 10W30
X X X X X * X X X								Fill fuel tank before starting Check engine oil Clean blower screen Remove debris from under belt cover Sharpen cutter blades Grease spindle bearings 2 pumps of hand gun Clean air filter/check for damage or loose parts Check/clean air intake and cooling areas ¹ Check tire pressure	Do not over fill MORE OFTEN IF NEEDED US Lithium MP White Grease 2125+ MORE OFTEN IF NEEDED MORE OFTEN IF NEEDED Add or adjust as required
		X						Service precleaner element ¹	
			X					Check battery electrolyte level	Distilled water only
				X X X X X X			Grease caster wheel bearings Grease idler arm pivots Service air cleaner element ¹ Change engine oil Check spark plug condition and gap Clean cooling areas ¹	Chassis grease Chassis grease See engine mfg. information See engine mfg. information	
					X X X X X X X X X X			Check all hardware for proper tightness Change engine oil filter Check hydro fluid reservoir level Clean and adjust spark plugs Grease rider frame pivot Grease control bell cranks Grease steering handle bearing Grease foot pedal bearings Grease rear wheel pivot (vertical) Grease rear wheel bearing	See engine mfg. information See engine mfg. information Chassis Grease Chassis Grease Chassis Grease Chassis Grease Chassis Grease Chassis Grease US Lithium MP White Grease 2125+
						X X		Drain hydraulic system and replace fluid Change hydrostatic oil filter	Use SAE 10W30 motor oil Clean area before removing filter

1. Perform these maintenance procedures more frequently under extreme dusty or dirty conditions.

TROUBLESHOOTING CUTTING CONDITIONS

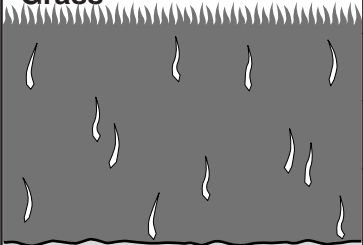
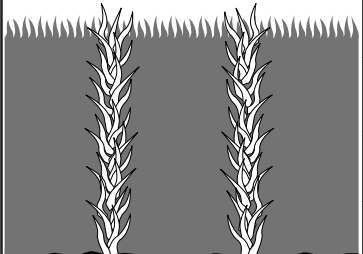
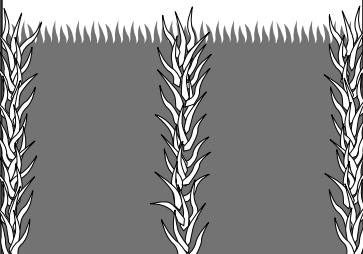
CONDITION	CAUSE	CURE
<p>Stringers - Occasional Blades of Uncut Grass</p>  <p>Width of Deck</p> <p>SGB020</p>	Low engine RPM	Run engine at full 3600 RPM
	Ground speed too fast	Slow speed to adjust for conditions
	Wet grass	Cut grass after it has dried out
	Dull blades, incorrect sharpening	Sharpen blades
	Deck plugged, grass accumulation	Clean underside of deck
<p>Streaking - Strips of Uncut Grass in Cutting Path</p>  <p>Width of Deck</p> <p>SGB018</p>	Dull, worn blades	Sharpen blades
	Incorrect blade sharpening	Sharpen blades
	Low engine RPM	Run engine at full 3600 RPM
	Belt slipping	Adjust belt tension
	Deck plugged, grass accumulation	Clean underside of deck
	Ground speed too fast	Slow speed to adjust for conditions
	Wet grass	Cut grass after it has dried out
<p>Streaking - Strips of Uncut Grass Between Cutting Paths</p>  <p>Width of Deck Width of Deck</p> <p>SGB019</p>	Not enough overlapping between rows	Increase the overlap of each pass

TROUBLESHOOTING

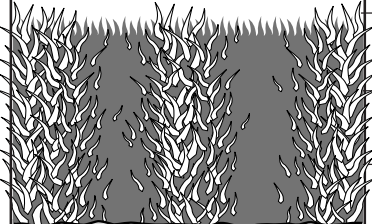
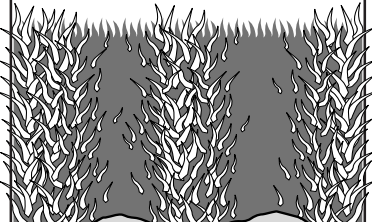
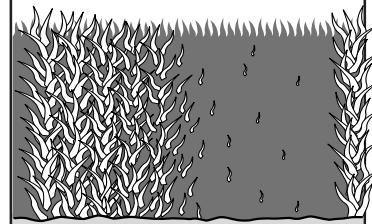
CONDITION	CAUSE	CURE
<p>Uneven Cut on Flat Ground - Wavy High-Low Appearance, Scalloped Cut, or Rough Contour</p>  <p>Width of Deck SGB020</p>	Lift worn off of blade	Replace blade
	Blade upside down	Mount with cutting edge toward ground
	Deck plugged, grass accumulation	Clean underside of deck
	Too much blade angle (deck pitch)	Adjust pitch and level
	Deck mounted improperly	See your authorized SCAG dealer
	Bent spindle area	See your authorized SCAG dealer
	Dull blade	Sharpen blade
<p>Uneven Cut on Uneven Ground - Wavy Appearance, High-Low Scalloped Cut, or Rough Contour</p>  <p>Width of Deck SGB021</p>	Uneven ground	May need to reduce ground speed, raise cutting height, and/or change direction of cut
<p>Sloping Ridge Across Width of Cutting Path</p>  <p>Width of Deck SGB023</p>	Tire pressures not equal	Check and adjust tire pressure
	Wheels uneven	Check and adjust tire pressure
	Deck mounted incorrectly	See your authorized SCAG dealer

TROUBLESHOOTING

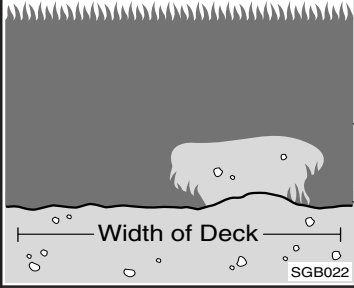
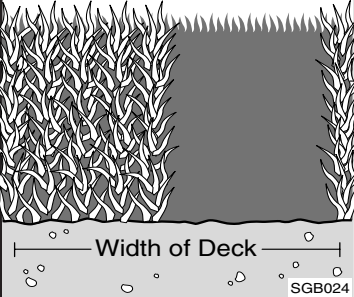
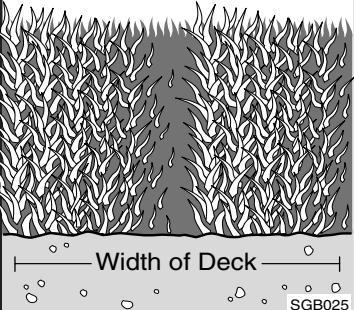
CONDITION	CAUSE	CURE
<p>Scalping - Blades Hitting Dirt or Cutting Very Close to the Ground</p>  <p>Width of Deck SGB022</p>	Low tire pressures	Check and adjust pressures
	Ground speed too fast	Slow speed to adjust for conditions
	Cutting too low	May need to reduce ground speed, raise cutting height, change direction of cut, and/or change pitch and level
	Rough terrain	May need to reduce ground speed, raise cutting height, and/or change direction of cut
	Ground speed too fast	Slow speed to adjust for conditions
<p>Step Cut Ridge in Center of Cutting Path</p>  <p>Width of Deck SGB024</p>	Blades not mounted evenly	Adjust pitch and level
	Bent blade	Replace blade
	Internal spindle failure	See your authorized SCAG dealer
	Mounting of spindle incorrect	See your authorized SCAG dealer
<p>Slope Cut - Sloping Ridges Across Width of Cutting Path</p>  <p>Width of Deck SGB025</p>	Bent spindle mounting area	See your authorized SCAG dealer
	Internal spindle failure	See your authorized SCAG dealer
	Bent deck housing	See your authorized SCAG dealer

TECHNICAL SPECIFICATIONS

ENGINES

General Type:	Heavy duty industrial/commercial
Brand:	Kohler 23 HP Pro Series (Spec PS-75523)
Models:	CV23S
Horsepower:	23HP @ 3600 RPM
Type:	4 cycle gas, twin cylinder, vertical shaft engine
Displacement:	23HP = 674 cc
Cylinders:	2 cast-iron sleeves
Governor:	Mechanical type governor with variable speed control set at 3600 rpm (± 50 rpm), idle set at 1900 rpm (± 100 rpm)
Air Intake Group:	Large capacity dual element, chopper-type grass screen
Exhaust Group:	Single exhaust canister muffler
Fuel Pump Group:	Mechanical fuel pump with inline fuel filter, fixed jet carburetor with Smart-Choke™ and fuel shutown solenoid
Oil Pump Group:	Positive displacement Gerotor™ oil pump. Capacity 2.0 U.S. Quarts with filter, standard oil cooler.
Valve Group:	Hydraulic valve lifters standard
Starter/Electrical:	12 volt battery with alternator, solid state ignition with key start
Charging System:	15 amp

ENGINE DECK

Fuel Tank:	5 gallon (19.0 litres) seamless polyethylene
Drive Wheels/Tires:	20x10.0-10 four-ply pneumatic tubeless, radius edge
Brakes:	Integral braking with drive system
Parking Brake:	Drum-type
Frame:	Hybrid tractor trailer frame with stabilized pivot

DRIVE SYSTEM

Type:	Hydro drive with one variable displacement pump and two cast-iron high torque motors
Hydro Pump:	#15 cast-iron variable displacement pump with remote dump valve for movement without running engine
Drive Wheel Motors:	12 cu. inch cast-iron high torque motors
Dump Valve:	Single lever allows for movement without engine running
Hydro Fluid Cooling Group:	Heavy-duty cooling radiator, 13 qt. capacity nylon cooling reservoir, uses, SAE 10W30 fluid and 10 micron filter
Travel Control:	Hydro drive with single foot pedal for forward and reverse speed control, infinitely variable speeds
Steering:	Aircraft-type yoke steering handle with stainless steel cable
Axles:	1-1/4" tapered motor shafts
Safety Group:	Foot actuated engine kill, brake interlock, blade/clutch interlock switch
Instrument Panel:	Ammeter, hour meter, key switch, throttle, fuses, manual choke, blade brake clutch switch
Forward Speed Range:	0 to 6.8 mph
Reverse Speed Range:	0 to 5.4 mph

TECHNICAL SPECIFICATIONS (CON'T)

CUTTER DECKS

Type:	SM61V, SM 72A Out-front design with anti-scalp roller and pneumatic shock absorber for deck flotation
Construction:	10-gauge steel with 7-gauge (3/16") steel skirt
Cutting Width:	61.0 " (155.0 cm), 71.5" (181.6 cm)
Cutting Height Adjustment:	Adjustable from 1-3/4" to 5-1/4" in 1/4" increments
Cutter Blades:	.197 Thick, Milled Edge, Wear Resistant Marbain™ SM61V: Three (3) 21" blades SM72A: Three (3) 24" blades
Blade Engagement:	Electric blade brake clutch with instrument panel switch
Lift System:	Patented manual winch with automatic brake/clutch, stainless steel cable
Discharge Opening:	Extra wide 11.5", 13.75 " discharge opening with hinged chute
Caster Wheels:	9 x 3.5 smooth tread flat free, roller bearings, with quick pin removal
Spindles:	Cast housing, taper roller bearing, low maintenance with top access grease fitting and grease overfill relief poppet
Pulleys:	Cast-iron with easily removed taper hubs
Cutter Deck Belts:	B-section with Kevlar cord

ADDITIONAL SPECIFICATIONS

Seat:	Foam padded, lever adjustment forward and back, with padded arm rests
-------	---

OPTIONAL ITEMS/ATTACHMENTS

Mulching Plate:	Steel plate fits over discharge opening. No blade change or removal required. Installs and removes in the field.
Hurricane Mulch Kit	The unique Hurricane Mulch System employs eye of the hurricane mulching plates combined with bolt-in v-baffles, flow directors, Eliminator blades, a side discharge close-off plate.
Electric Deck Lift:	Lift mounts to the side of the rider frame assembly to raise and lower the deck at the flip of a switch.
Cup Holder:	12 Gauge Steel with rubber retainer.

APPROXIMATE DIMENSIONS

	SM61V	SM72A
Length:	113.0"	118.0"
Length with Grass Catcher:	137.0"	142.0"
Tracking Width:	50.0"	50.0"
Width:	70.0"	81.0"
Width (with discharge chute up):	63.0"	74.0"
Width with GCV grass catcher:	70.0"	84.0"
Height:	43.0"	43.0"
Height with GCV grass catcher:	51.5"	51.5"
Weight:	950 lbs.	1000 lbs.
Weight with GCV grass catcher:	1250 lbs.	1300 lbs.

NOTES

SM-61V & SM-72A CUTTER DECK

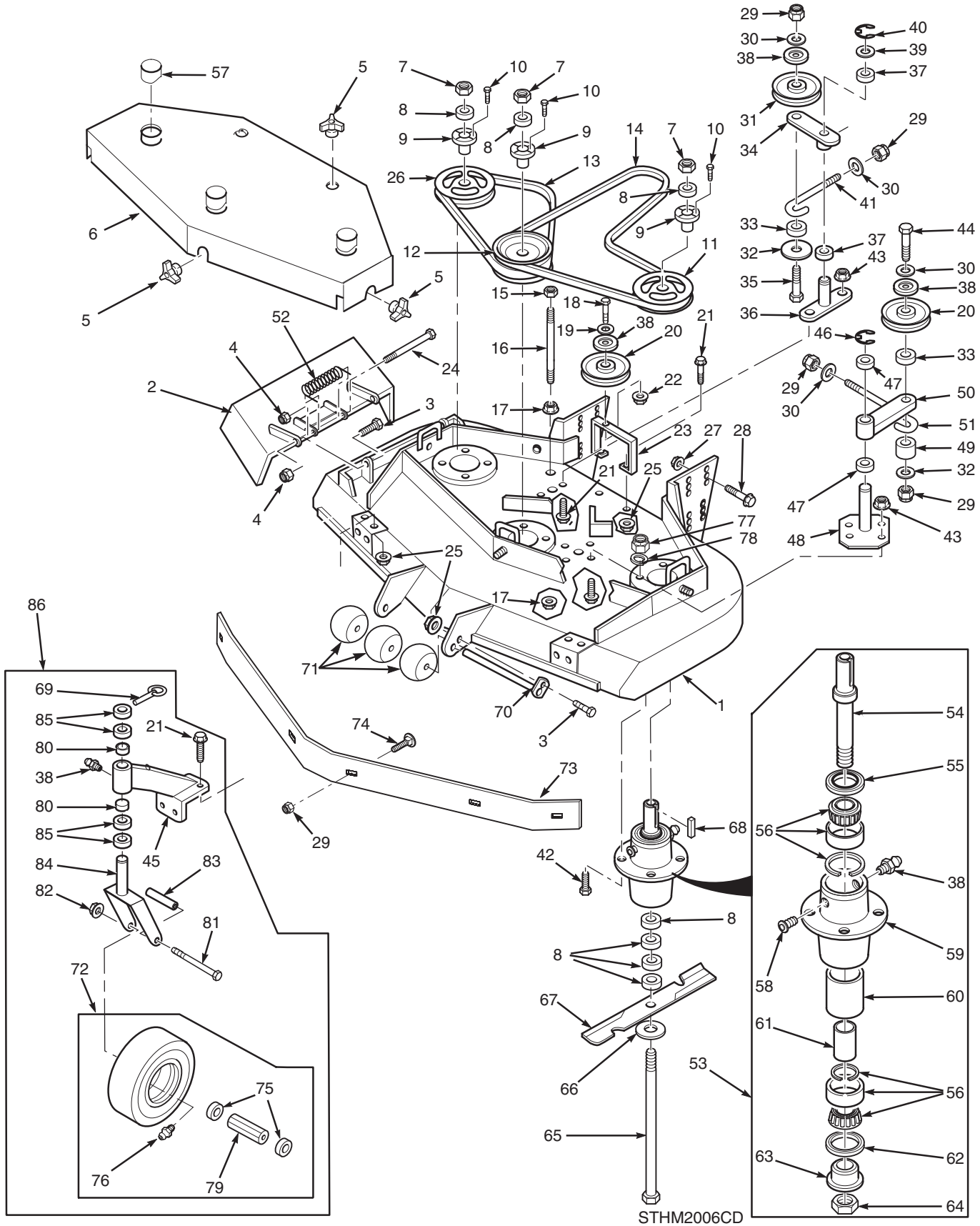

SM-61V & SM-72A CUTTER DECK

Ref. Part No.	Description	61	72	Ref. Part No.	Description	61	72
1	461861 Cutter Deck, Velocity + (Incl. decals)	x		43	04019-03 Nut, 5/16-18 Ser. Flange	x	x
1	461864 Cutter Deck, Advantage (Incl. decals)		x	44	04001-77 Bolt, 3/8-16 x 3-1/2" Hex Head	x	x
2	461846 Discharge Chute, Velocity Plus	x		45	46082 Support Assembly	x	x
	461296 Discharge Chute, Advantage		x	46	04050-05 Retaining Ring, 1-1/8 EXT 'E'	x	x
3	04001-09 Bolt, 5/16-18 x 1" Hex Head	x	x	47	48224 Bearing	x	x
4	04021-10 Nut, 5/16-18 Elastic Stop	x	x	48	45329 Idler Pivot Support	x	x
5	04029-03 Wing Nut, 3/8-16	x	x	49	43277 Spacer	x	x
6	461583 Belt Cover (Incl. Decals)	x		50	461841 Idler Arm (Incl. 47)	x	x
6	46848 Belt Cover (Incl. Decals)		x	51	44078 J-Rod, Drive Idler	x	x
7	04020-09 Nut, 5/8-11 Hex Head	x	x	52	482245 Spring, Chute Return	x	x
8	43592 Spacer, Cutter Blade	x	x	53	461663 Spindle Assembly	x	x
9	48926 Tapered Hub, 1.125 Bore	x	x	54	43589 Shaft, Cutter Spindle	x	x
10	04001-172 Bolt, 1/4-20 x 1" Hex Head Grade 8	x	x	55	481024 Seal, 2.00 O.D. x 1.50 Bore	x	x
11	482745 Pulley, 6.35 O.D.	x		56	481022 Bearing Assembly	x	x
	482747 Pulley, 6.95 O.D.		x	57	48098 Shield, Spindle	x	x
12	48940 Pulley, Double Groove, 6.35/5.75 O.D.	x		58	48677 Relief Fitting, Cutter Spindle	x	x
	48966 Pulley, Double Groove, 6.95/5.75 O.D.		x	59	43664 Spindle Housing	x	x
13	48265 Belt, R.H. Blade Drive	x		60	43312 Spacer, Outside	x	x
	48295 Belt, R.H. Blade Drive		x	61	43296 Spacer, Inside	x	x
14	48912 Belt, Deck Drive	x		62	481025 Seal, 2.00 O.D. x 1-5/8 Bore	x	x
	481001 Belt, Deck Drive		x	63	43297 Spindle Bushing Bottom	x	x
15	04021-05 Lock Nut, 3/8-16 Hex Head	x	x	64	481035 Nut, 1-1/16-18 UNEF-2B	x	x
16	04004-14 Stud, 3/8-16 x 6-3/4"	x	x	65	04001-41 Bolt, 5/8-11 x 9-1/2"	x	x
17	04019-04 Nut, 3/8-16 Serr. Flange	x	x	66	04040-10 Flatwasher, 5/8 (.688 x 1.75 x .134)	x	x
18	04001-46 Bolt, 3/8-16 x 2-1/4"	x	x	67	482879 Cutter Blade, 21" Standard	x	
19	04041-07 Flatwasher, 3/8 (.391 x .938 x .105)	x	x		482880 Cutter Blade, 24" Standard		x
20	483215 Pulley, Idler	x	x	68	04063-08 Key, 1/4 x 1/4 x 2"	x	x
21	04017-16 Capscrew, 5/16-18 x 3/4 Ser. Flg. HH	x	x	69	04066-01 Quick Pin	x	x
22	04021-09 Nut, 3/8-16 Elastic Stop	x	x	70	45944 Shaft, Roller	x	x
23	421355 Idler Pulley Support	x	x	71	482295 Guide, Roller	x	x
24	04001-108 Bolt, Hex Head 5/16-18 x 4-1/4"	x	x	72	9275 Wheel Assy., Caster	x	x
25	04019-03 Nut, 5/16-18 Ser. Flg. Hex Hd.	x	x	73	424164 Baffle, Custom-Cut 61V	x	
26	482744 Pulley, 5.75	x	x		423795 Baffle, Custom-Cut 72A		x
27	04019-06 Nut, 1/2-13 Ser. Flg. Hex Hd.	x	x	74	04003-23 Bolt, Carriage 3/8-16 x 1"	x	x
28	04017-37 Capscrew, 1/2-13 x 1-1/4 Ser. Flg.	x	x	75	481770 Retainer, Caster Wheel	x	x
29	04021-09 Nut, 3/8-16 Elastic Stop	x	x	76	48114-03 Grease Fitting, 45 Deg. 1/4-28	x	x
30	04041-07 Flatwasher, 3/8 (.391 x .938 x .105)	x	x	77	04021-22 Nut, Elastic Stop 5/16-18 Grade 8	x	x
31	48181 Pulley	x	x	78	04030-03 Lock Washer, 5/16"	x	x
32	04041-12 Flatwasher, 3/8 (.375 x 1.50 x .060)	x	x	79	481769 Roller Bearing, Caster Wheel	x	x
33	43077 Spacer	x	x	80	48100-01 Bushing, 7/8 x 1" Flanged	x	x
34	461091 Idler Arm (Incl. 37)	x	x	81	04001-37 Bolt, 1/2-13 x 5-1/2" Hex Head	x	x
35	04001-46 Bolt, 3/8-16 x 2-1/4"	x	x	82	04021-07 Nut, 1/2-13 Elastic Stop	x	x
36	45037 Idler Pivot	x	x	83	43022 Sleeve, Caster Wheel Bearing	x	x
37	48224 Bearing	x	x	84	45006 Caster Yoke	x	x
38	424367 Dust Shield	x	x	85	43037-01 Spacer, Caster Yoke 1/2"	x	x
39	04041-08 Flatwasher, 3/4 (.776 x 1.25 x .059)	x	x	86	46079 Caster Wheel and Support Assy.	x	x
	04041-08S Flatwasher, 3/4 (.776 x 1.25 x .035)		x				
40	04050-02 Retaining Ring, .75 EXT 'E'	x	x				
41	43028 J-Rod Idler Pulley	x					
	44078 J-Rod Idler Pulley		x				
42	04001-175 Bolt, 5/16-18 x 1-1/2" Hex Head Gr 8	x	x				

ENGINE DECK

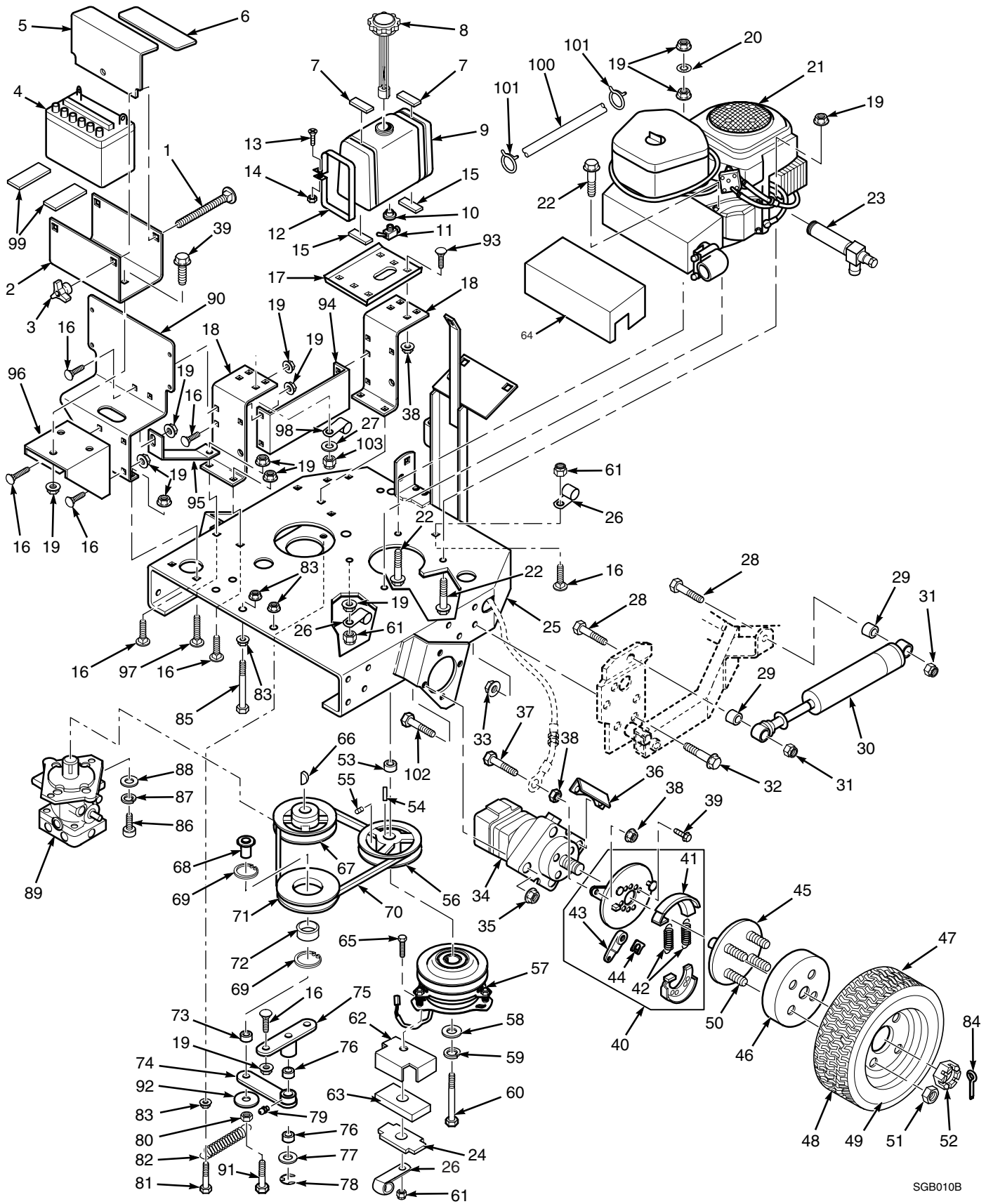

SGB010B

ENGINE DECK

Ref. Part No.	Part Number	Description	Ref. Part No.	Part Number	Description
1	04003-01	Carriage Bolt, 1/4-20 x 6"	54	04063-08	Key, 1/4 x 1/4 x 2"
2	423308	Battery Box	55	04012-04	Hex Socket Set Screw, 5/16-18 x 3/8"
3	04029-01	Nut, Wing 1/4-20	56	48792	Pulley, Engine Pump Drive (Incl. 55)
4	48015	Battery	57	461397	Clutch, Electric (Ogura)
5	42392	Battery Cover	58	04041-28	Flatwasher, 7/16 (.469 x 1.75 x .25)
6	48099	Insulation, Battery Cover	59	04030-05	Lockwasher, 7/16"
7	48292	Pad, Fuel Tank Strap	60	04102-05	Bolt, Hex Head 7/16-20 x 2.75"
8	481556	Cap, Fuel Tank	61	04021-10	Hex Locknut, Elastic Stop 5/16-18
9	46846	Fuel Tank Assy. (Includes items 10 - 11)	62	422533	Backing Plate, Clutch Stop
10	48309	Bushing, Fuel Tank Valve	63	481716	Rubber Pad, Clutch Stop
11	48308	Fuel Shut Off Valve	64	481641	Heatshield, Muffler
12	421239	Strap, Fuel Tank	65	04001-12	Bolt, Hex Head 5/16-18 x 1-3/4"
13	04010-10	Phil RDHD Machine Screw 1/4-20 x 2"	66	04063-12	Key, Woodruff 3/16 x 5/8"
14	04020-02	Hex Nut, 1/4-20	67	48581	Pulley, Pump Input
15	48205	Pad, Fuel Tank Support	68	43117	Sleeve, Idler
16	04003-12	Carriage Bolt, 5/16-18 x 3/4"	69	04050-06	Ring, Retaining, 1-9/16 Internal
17	42377	Support, Fuel Tank	70	48854	Belt, Pump Drive
18	421522	Bracket, Fuel Tank Support	71	46370	Pulley, Idler-Traction Drive (Incl. 68,69,72)
19	04019-03	Serr. Fl. Hex Nut 5/16-18	72	48102	Bearing, Idler Pulley
20	04031-09	Lockwasher, 5/16 Int. Tooth	73	43063	Spacer, Idler
21	481776	Engine, 23 HP Kohler CV, (Spec PS-75523)	74	46327	Pump Idler Arm (includes items 76, 79)
22	04001-12	Hex Head CPSCR, 5/16-18 x 1-3/4"	75	45037	Idler Pivot Base
23	482352	Oil Drain Extension	76	48100-05	Bushing, Oiltube
24	422534	Plate, Backing	77	04041-08S	Flatwasher, 3/4"
25	45586	Engine Deck	78	04050-02	Ring, Retaining, 3/4" Ext. "E"
26	48030-09	Wire Loom, .50 I.D.	79	48114-04	Grease Fitting
27	04040-14	Washer, 1/4 (.312 x .750 x .065)	80	04020-12	Hex Nut, Jam 3/8-16
28	04001-72	Bolt, Hex Head 1/2-13 x 2"	81	04001-62	Bolt, Hex Head 3/8-16 x 3-1/4"
29	43041	Sleeve, Shock Absorber Mount	82	48929	Spring, Pump Drive Idler
30	48516	Shock Absorber	83	04019-04	Serr. Fl. Hex Nut, 3/8-16
31	04021-07	Hex Locknut, Elastic Stop 1/2-13	84	04061-04	Cotter Pin, 5/32 x 1.50"
32	04017-42	Serr. Fl. Hex Head CPSCR, 7/16-14 x 1"	85	04001-47	Bolt, Hex Head 3/8-16 x 5"
33	04019-05	Serr. Fl. Hex Nut, 7/16-14	86	04015-03	Socket Head CPSCR, 1/2-13 x 1-1/4"
34	48769	Motor - White (Includes item 52)	87	04030-06	Lockwasher, 1/2"
35	04030-06	Lockwasher, 1/2"	88	04041-04	Flatwasher, 1/2 (.516 x .938 x .105)
35A	04020-07	Nut, 1/2-13	89	481100	Pump, Sundstrand
36	421289	Anchor, Brake	90	421520	Bracket, Oil Tank Support
37	04001-59	Bolt, Hex Head 1/4-20 x 1-1/4"	91	04001-21	Bolt, Hex Head 3/8-16 x 1-3/4"
38	04019-02	Serr. Fl. Hex Nut, 1/4-20	92	04041-10	Washer 2" OD, 3/8 ID, 16 Ga.
39	04017-16	Serr. Fl. Hex Head CPSCR, 5/16-18 x .75"	93	04003-02	Carriage Bolt, 1/4-20 x 3/4"
40	48461	Parking Brake Assembly (Incl. 41-44)	94	421523	Guard, Pulley
41	48461-02	Brake Pads- Pair	95	421521	Gusset, Battery Box
42	48461-03	Springs - Pair	96	421705	Support, Battery Box
43	48461-04	Actuating Arm, Incl. Pin & Clip	97	04003-04	Carrage Bolt, 5/16-18 x 1"
44	48461-05	Clip	98	48030-10	Wire Loom, .75" I.D.
45	46929	Hub Assembly (Includes item 50)	99	48661	Rubber Pad
46	48513	Brake Drum	100	48058	Fuel Hose, Order by the inch
47	48933	Rim and Tire Assembly (Includes items 48, 49)	101	48059-01	Clamp, Fuel Hose
48	48933-02	Tire 20 x 10 x 10, 4 Ply	102	04001-52	Bolt, 1/2-13 x 2.50"
49	48416-04	Rim Only	103	04021-08	Nut, 1/4-20 Elastic Stop
50	04008-03	Bolt, Hub			
51	04028-01	Wheel Nut			
52	48680	Castle Nut, 1.0-20 UNEF			
53	43261	Spacer, Clutch			

UPPER HYDRAULICS

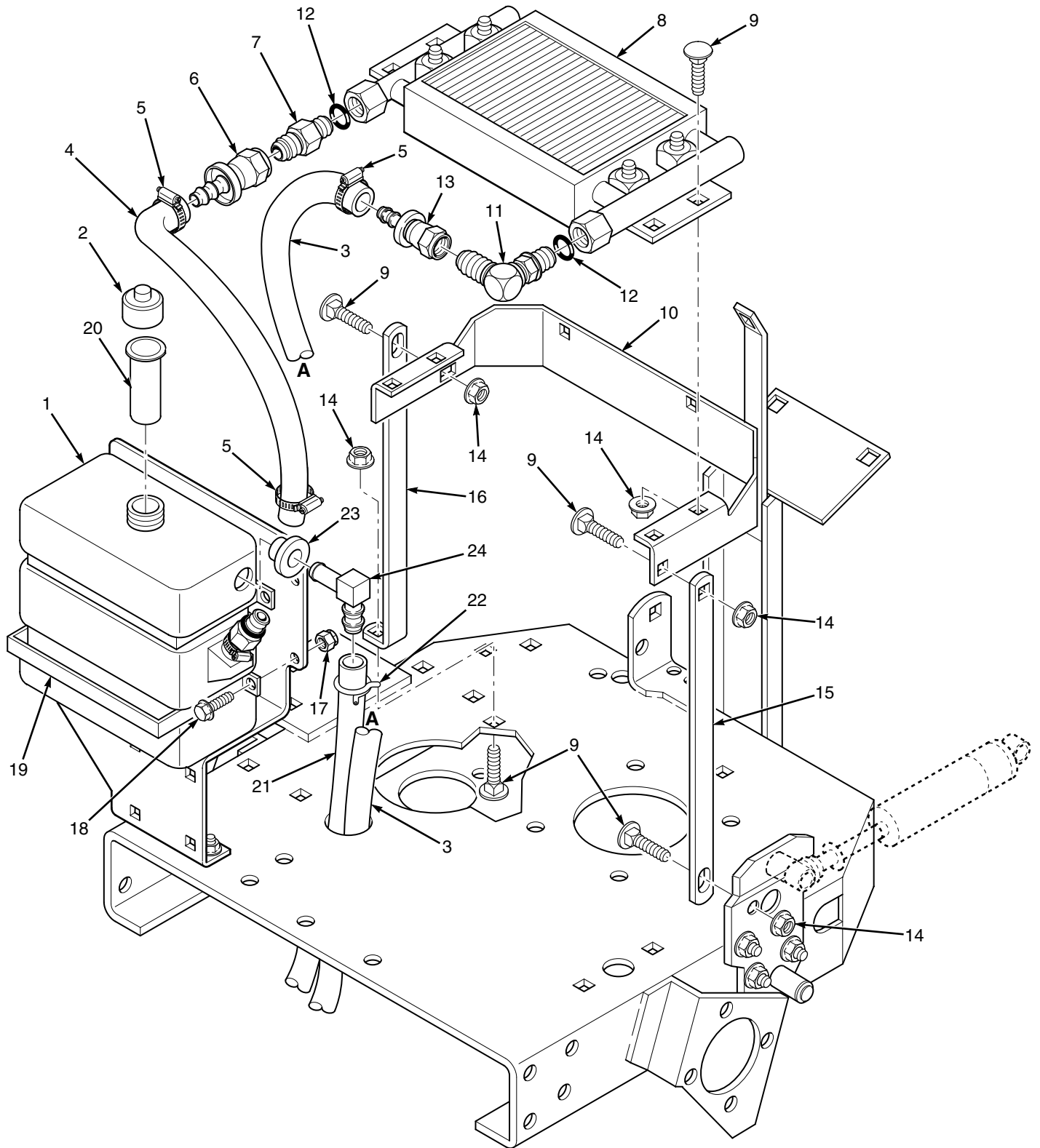

UPPER HYDRAULICS

Ref. No.	Part Number	Description
1	48711	Tank, Hydraulic
2	481164	Cap, Hydraulic Tank
3	48634	Hose, Pump to Oil Cooler
4	48942	Hose, Oil Cooler to Tank
5	48136-04	Clamp, Hose
6	48936-01	Coupling, Flare Swivel
7	48572-05	Tube, Union
8	48645	Oil Cooler Assembly
9	04003-12	Carriage Bolt, 5/16-18 x 3/4"
10	421279	Bracket, Oil Cooler
11	48350-05	Elbow, 90 Degrees
12	48603-02	O-Ring
13	48936-02	Coupling Flare Swivel
14	04019-03	Serr. Fl. Hex Head Nut, 5/16-18
15	421280	Brace, L.H. Cooler Support
16	421281	Brace, R.H. Cooler Support
17	04021-08	Elastic Stop Nut, 1/4-20
18	04017-05	Serr. Fl. Hex Head CPSCR, 1/4-20 x 3/4"
19	421288	Strap, Oil Tank
20	481507	Filler Neck Insert
21	48482	Hose, 1/4" Pushlock, Order by the inch
22	48059-01	Clamp
23	48309	Bushing
24	48939	90 Degree Elbow

LOWER HYDRAULICS

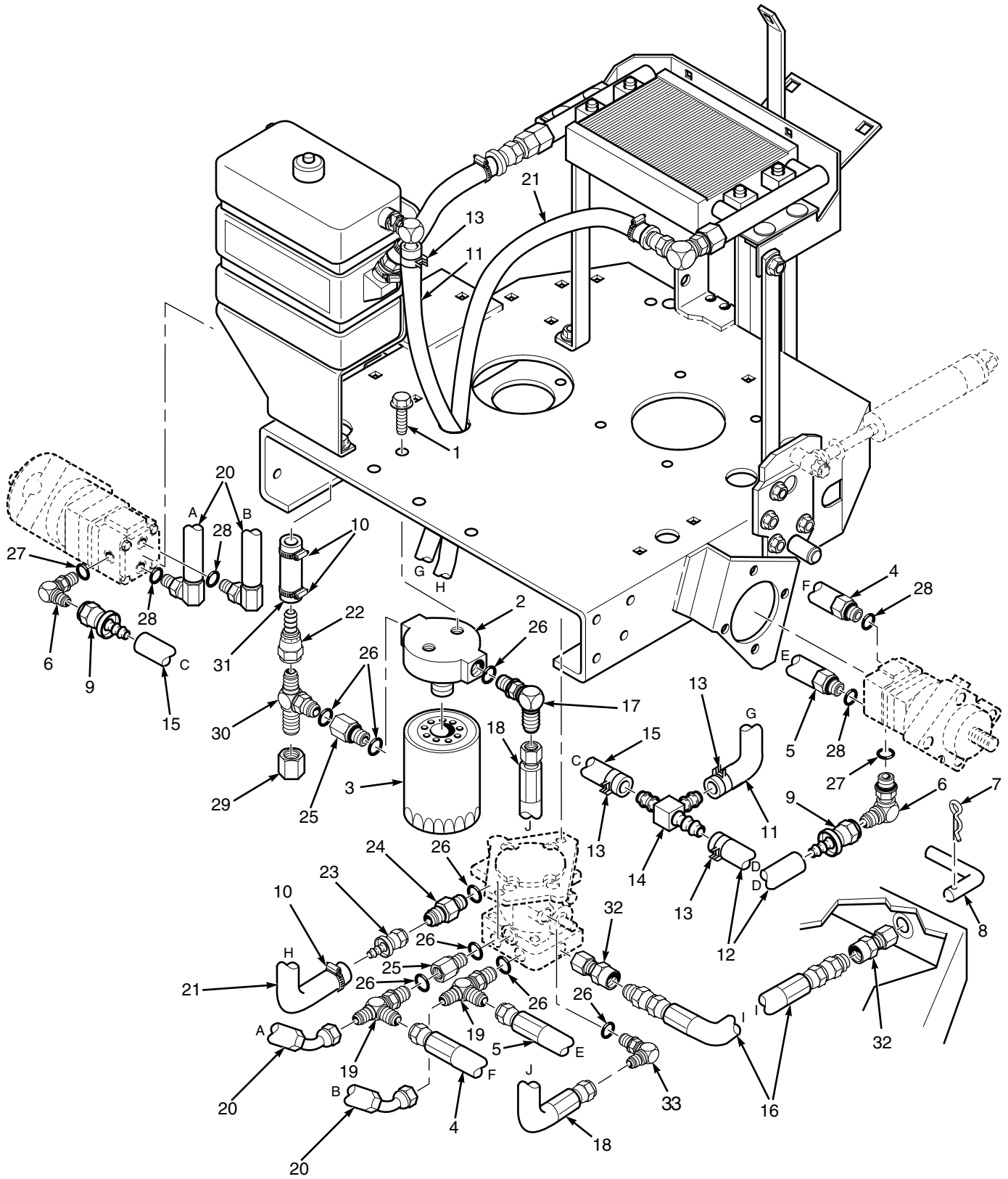

LOWER HYDRAULICS

Ref. No.	Part Number	Description
1	04017-04	Capscrew, 1/4-20 x1/2 Serr. Fl. Hex Head
2	48462-02	Filter Head
3	48758	Filter, Spin-On Lube
4	48991	Hose Assembly
5	48688	Hose Assembly
6	48350-03	Elbow, 90 Degrees
7	04062-01	Hairpin Cotter
8	44088	Lever, Dump Valve
9	48353-02	Connector, Flare Swivel with Hose Barb
10	48136-04	Hose Clamp
11	48482	Hose, 1/4 Pushlock, Order by the inch
12	48482	Hose, 1/4 Pushlock, Order by the inch
13	48059-01	Hose Clamp
14	48935-01	Tee Union, Pushlock Hose
15	48482	Hose, 1/4 Pushlock, Order by the inch
16	48853	Hose, Dump Valve
17	48350-05	Elbow, 90 Deg.
18	48856	Inlet Hose, 3/4" ID
19	48937-01	Tee, 1/2" Run
20	48905	Motor Hose
21	48634	Hose, Pump To Oil Cooler
22	48936-01	Coupling, Flare Swivel
23	48936-02	Coupling, Flare Swivel With Barb
24	48572-06	Tube Union
25	48938-01	O-Ring Bushing
26	48603-02	O-Ring
27	48603-03	O-Ring
28	48603-04	O-Ring
29	48571-03	Cap
30	48810-02	Tee, JIC to O-Ring
31	48602	Hose, Order by the inch
32	48911-01	Compression Fitting
33	48350-12	Elbow, 90 Deg.

CONTROL LINKAGE

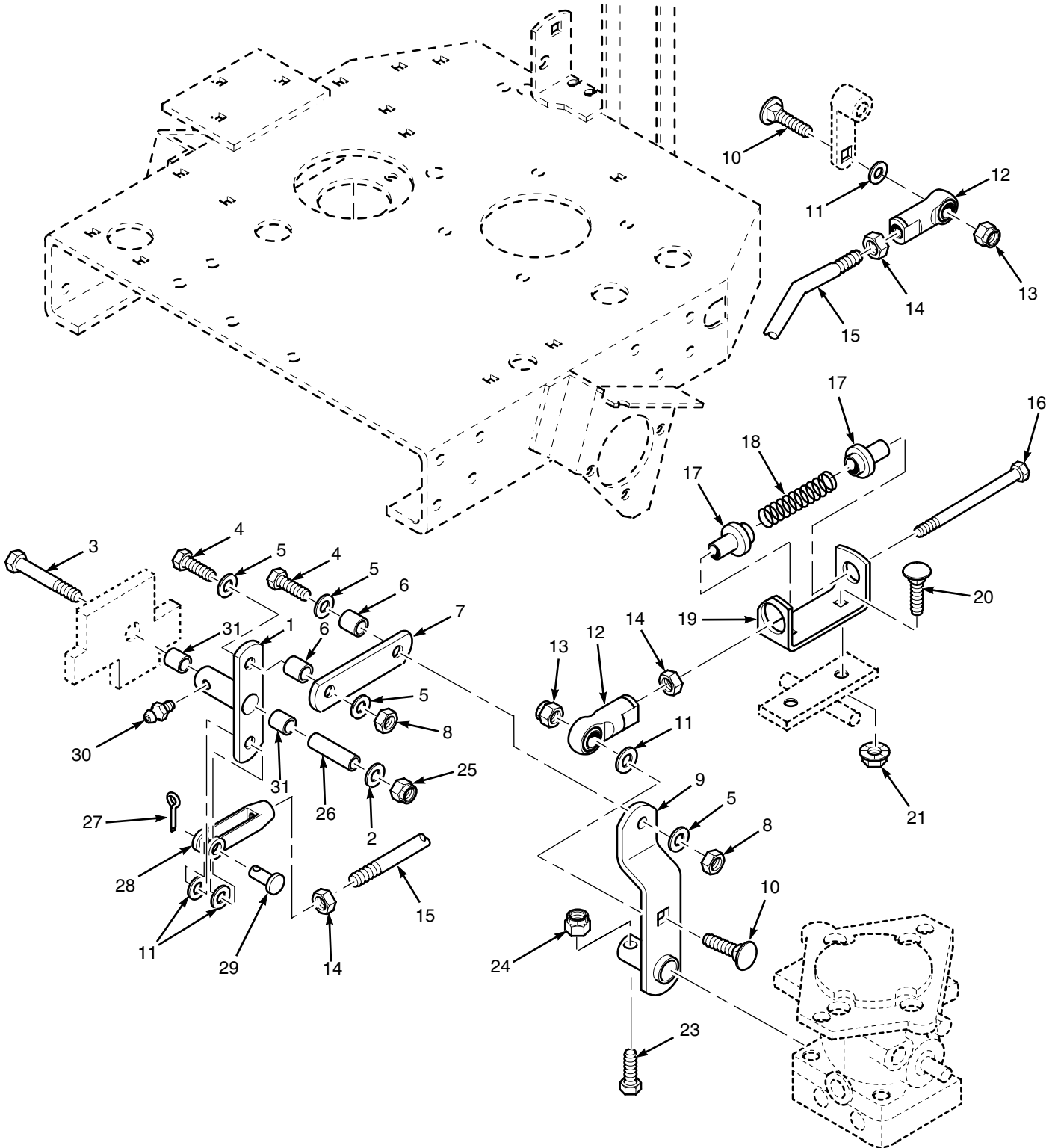

sgb011

CONTROL LINKAGE

Ref. No.	Part Number	Description
1	46328	Control Linkage, Bellcrank (Includes 30, 31)
2	04040-15	Flatwasher, 5/16 (.375 x .875 x .083)
3	04001-13	Bolt, Hex Head 5/16-18 x 2-3/4"
4	04001-19	Bolt, Hex Head 3/8-16 x 1"
5	04040-05	Flatwasher, 3/8 (.406 x .812 x .065)
6	43212	Sleeve, Pump Control Link
7	42658	Link, Speed Control
8	04021-05	Hex Locknut, 3/8-16
9	45485	Control Arm, Pump
10	04003-05	Carrage Bolt,RH SH SQNK 3/8-16 x 1-1/2"
11	04041-07	Flatwasher, 3/8 (.391 x .938 x .105)
12	48464	Rod End, RH Female THD 3/8-24
13	04021-09	Hex Locknut, Elastic Stop 3/8-16
14	04020-14	Hex Nut, 3/8-24
15	44044	Control Rod
16	48512	Bolt Hex Head, 3/8-24 x 6-3/4"
17	43257	Bushing, Spring Keeper
18	48463	Spring, Neutral Return
19	421148	Retainer, Neutral Spring
20	04003-04	Carrage Bolt, 5/16-18 x 1"
21	04019-03	Serr. Fl. Hex Nut 5/16-18
22	**	Number Not Used
23	04001-59	Bolt, Hex Head 1/4-20 x 1-1/4"
24	04021-08	Hex Locknut, Elastic Stop 1/4-20
25	04021-10	Hex Locknut, Elastic Stop 5/16-18
26	43110	Sleeve, Control Arm
27	04061-02	Cotter Pin, 3/32 x .75"
28	48343-04	Clevis, Pump Control
29	04064-02	Pin, Clevis 3/8"
30	48114-05	Greese Fitting, 1/4-28 Self Tap
31	48100-04	Bushing, Bronze

INSTRUMENT PANEL AND ELECTRICAL COMPONENTS

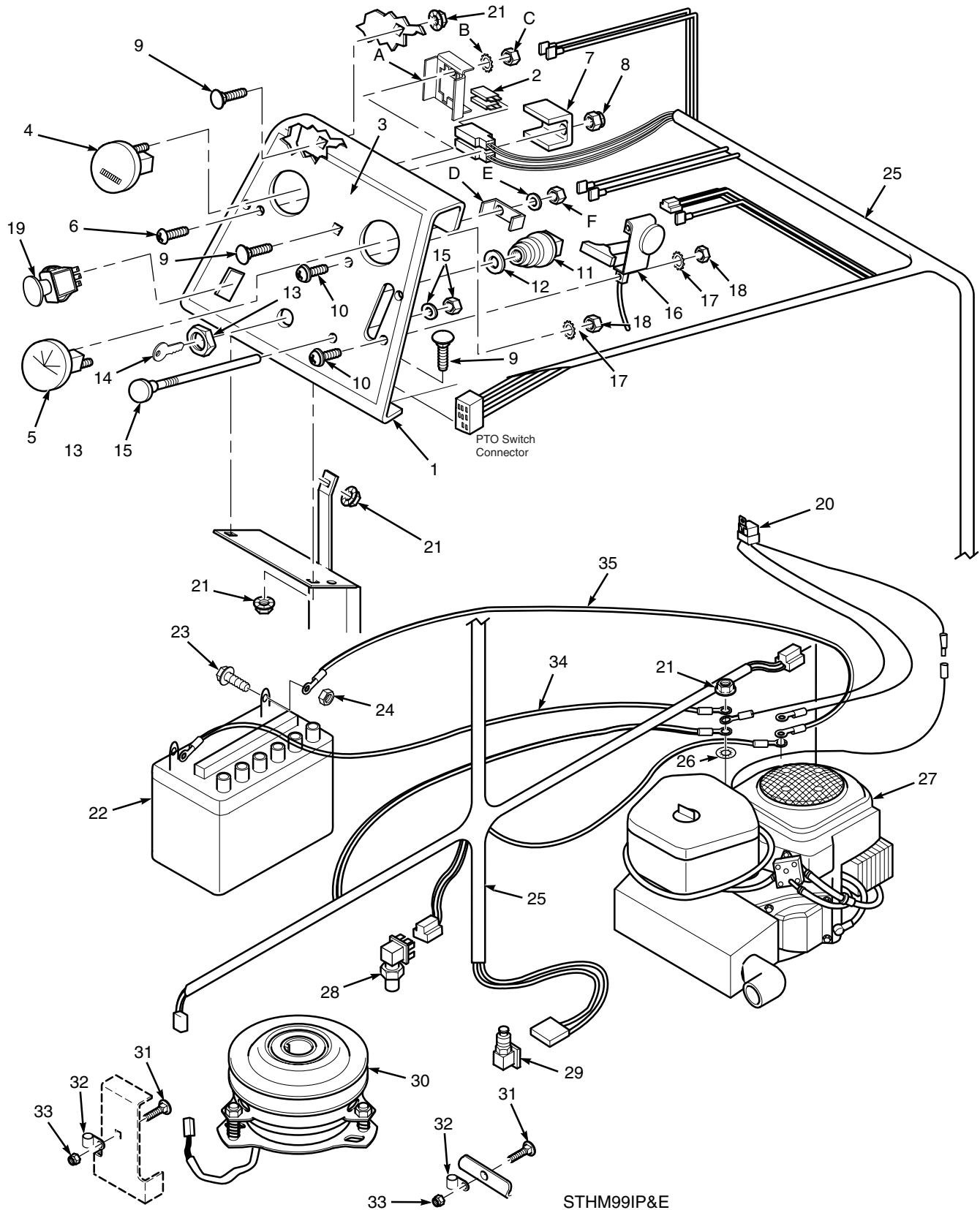

INSTRUMENT PANEL AND ELECTRICAL COMPONENTS

Ref. Part No.	Part Number	Description
1	461360	Instrument Panel (includes Decal)
2	48298	Blade Fuse, 20 amp.
3	482289	Decal, Instrument Panel
4	48023	Hour Meter (includes Bracket and Hardware A, B, C)
A	*	Hour Meter Bracket
B	*	Lockwasher, #10 Ext. Tooth
C	*	Hex Nut, 10-24
5	481755	Ammeter (includes Bracket and Hardware D, E, F)
D	*	Ammeter Bracket
E	*	Lockwasher, #10 Int. Tooth
F	*	Hex Nut, #10-32
6	04010-11	Phillips Rd. Head Screw, #10-32 x 1-1/2"
7	42413	Bracket, Fuse Holder
8	04021-01	Elastic Stop Nut, #10-32
9	04003-12	Carriage Bolt, 5/16-18 x 3/4"
10	04010-01	Phillips Washer Head Screw, #10-32 x .50"
11	48798	Keyswitch
12	*	Lockwasher, 5/8 Int. Tooth
13	*	Nut, Special 5/8-32
14	48017-02	Ignition Key and Ring Assy.
15	482315	Choke Control
16	48879	Throttle Control
17	04031-01	Lockwasher, #10 Ext. Tooth
18	04020-01	Hex Nut, #10-32
19	483162	Switch, PTO
20	481275	Wire Harness With Relay
21	04019-03	Serr. Fl. HH Nut, 5/16-18
22	482700	Battery (Not sold through Scag)
23	04001-44	Bolt, Hex head 1/4-20 x 1/2"
24	04020-02	Hex Nut 1/4-20
25	481683	Wire Harness, STHM
26	04031-09	Lockwasher 5/16 Int. Tooth
27	481776	Engine, 23 HP Kohler CV(Spec PS-75523)
28	481474	Switch, Parking Brake
29	481476	Switch, Foot Safety
30	461397	Clutch, Electric
31	04003-12	Carriage Bolt, 5/16-18 x 3/4"
32	48030-09	Wireloom
33	04021-10	Locknut, Elastic Stop 5/16-18
34	48029-15	Battery Cable, 36" Black
35	48029-13	Battery Cable, 25" Red

RIDER FRAME ASSEMBLY

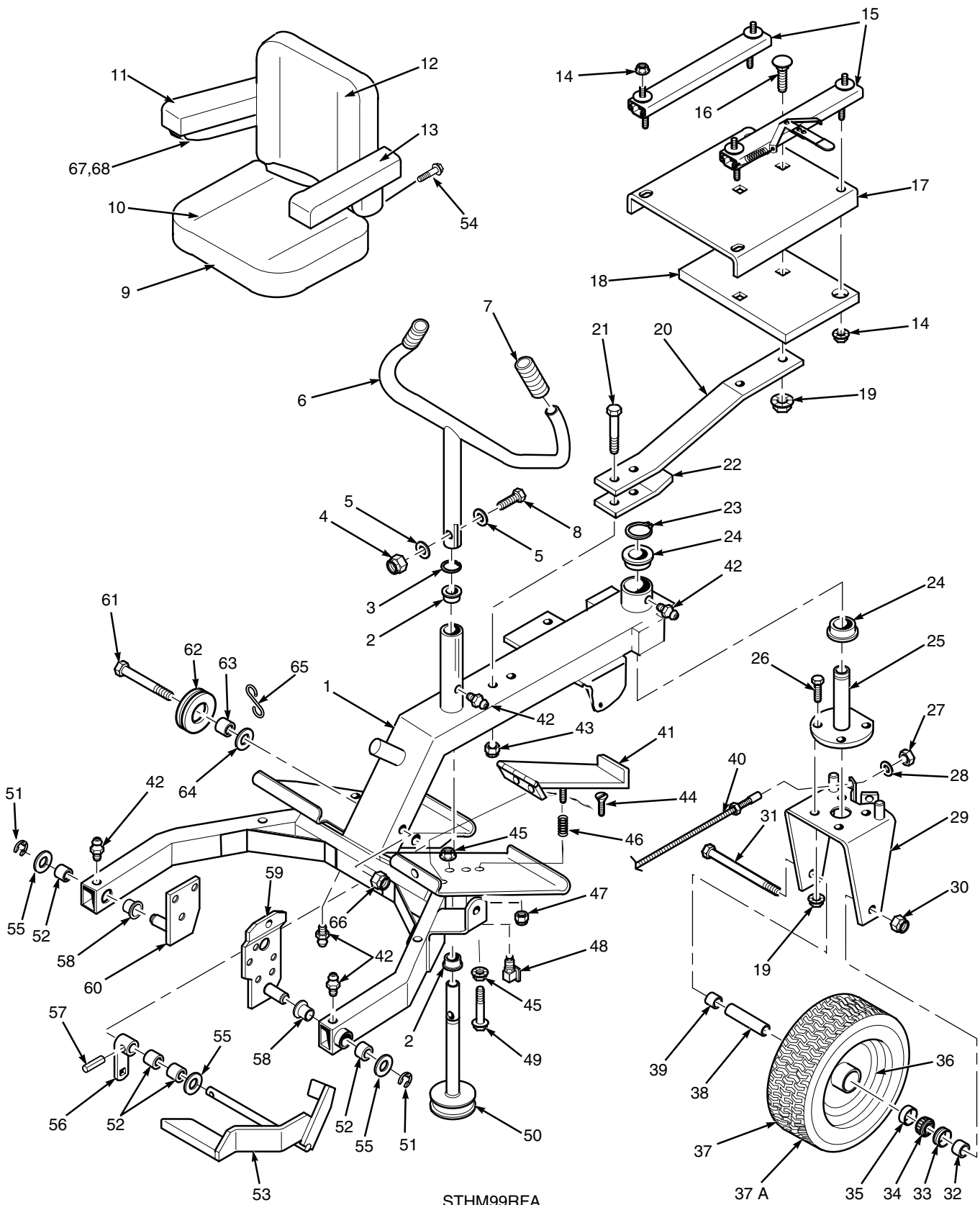

STHM99RFA

RIDER FRAME ASSEMBLY

Ref. Part No. Number	Description	Ref. Part No. Number	Description
1	46715	36	481894
2	48100-01	37	48005
3	04050-03	37A	481893
4	04021-10	38	43021
5	04040-15	39	43020-02
6	46029	40	48828
7	48159	41	45606
8	04001-12	42	48114-04
9	482119	43	04021-11
10	482111	44	04010-17
11	482108	45	04019-02
12	482105	46	481056
13	482107	47	04021-08
14	04019-03	48	481476
15	46570	49	04001-02
16	04003-05	50	45009
	04003-03	51	04050-02
17	421342	52	48100-06
18	42482	53	45502
19	04019-04	54	04010-22
20	42026	55	04041-08
21	04001-83	56	45506
22	42366	57	04065-01
23	04050-05	58	48100-03
24	48100-02	59	45488
25	45008	60	45256
26	04001-32	61	04001-37
27	*	62	48208
28	*	63	48100-04
29	45035	64	04040-13
30	04021-13	65	44028
31	04001-40	66	04021-07
32	43020-01	67	482109
33	481897	68	482110
34	481896		
35	481895		

BRAKE LINKAGE

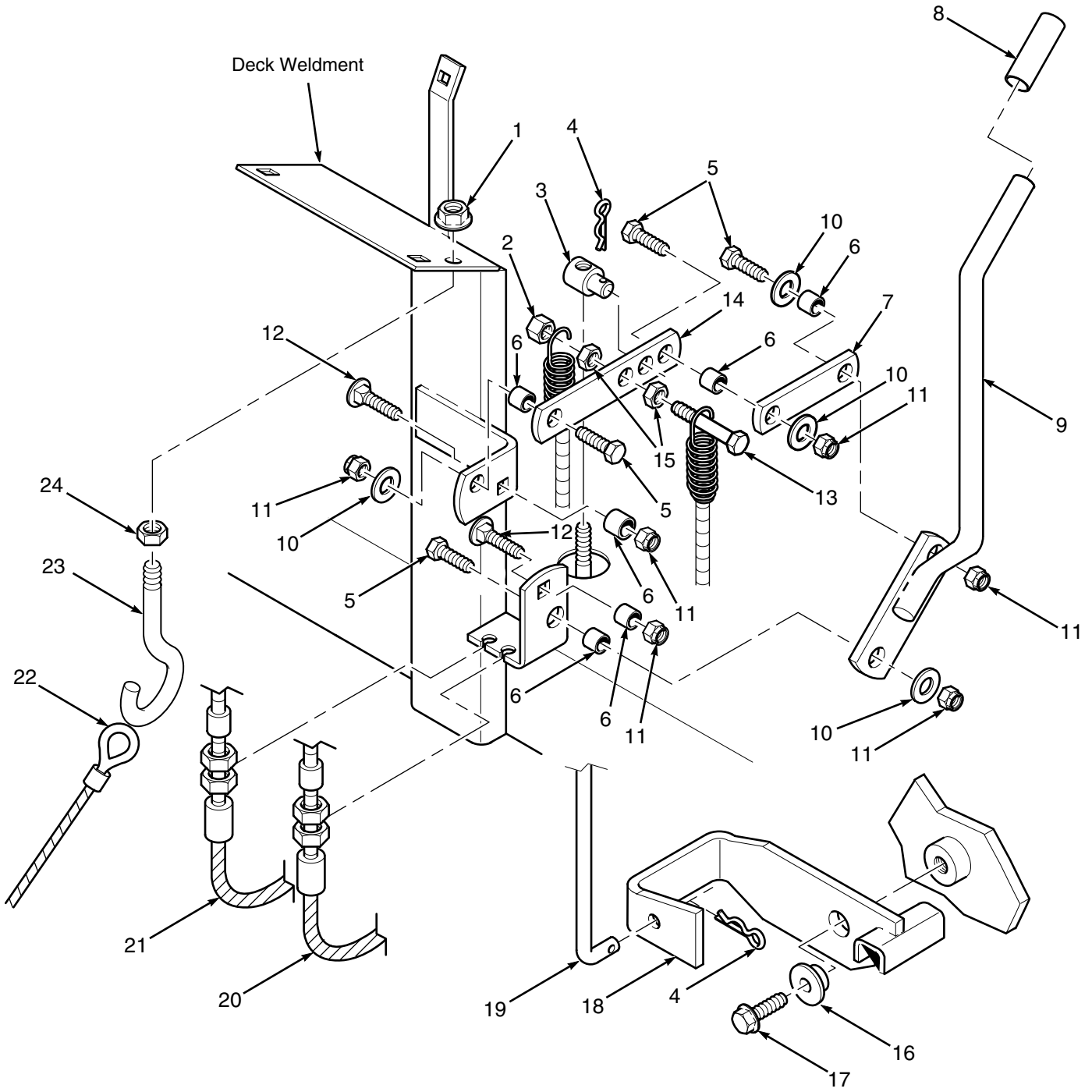

SGB050

BRAKE LINKAGE

Ref. No.	Part Number	Description
1	04019-04	Serr. Fl. HH Nut, 3/8-16
2	04021-05	Hex Locknut, 3/8-16
3	43032	Swivel
4	04062-01	Hairpin Cotter (.094 x 1.62)
5	04001-32	Hex Head Bolt, 3/8-16 x 1-1/4"
6	43212	Sleeve, Hydro Linkage
7	421338	Link, Cam
8	48342	Grip, Parking Brake
9	45504	Handle, Parking Brake
10	04041-07	Flat Washer, 3/8 (.391 x .938 x .105)
11	04021-09	Hex Nut, Elastic Stop 3/8-16
12	04003-11	Carriage Bolt, 3/8-16 x 1-1/4"
13	04001-21	Hex Head Bolt, 3/8-16 x 1-3/4"
14	421339	Lever, Brake
15	04020-12	Hex Jam Nut, 3/8-16
16	43260	Washer, Neutral Lock
17	04017-27	Serr. Fl. HH CPSCR, 3/8-16 x 1"
18	45647	Bracket, Neutral Lock
19	44085	Rod, Neutral Lock
20	48881	Cable Assembly, Parking Brake R.H.
21	48880	Cable Assembly, Parking Brake L.H.
22	48045	Cable Winch
23	04070-03	Eye Bolt, 3/8-16 R.H.
24	04020-04	Hex Nut, 3/8-16

ELECTRICAL WIRING HARNESS 481683

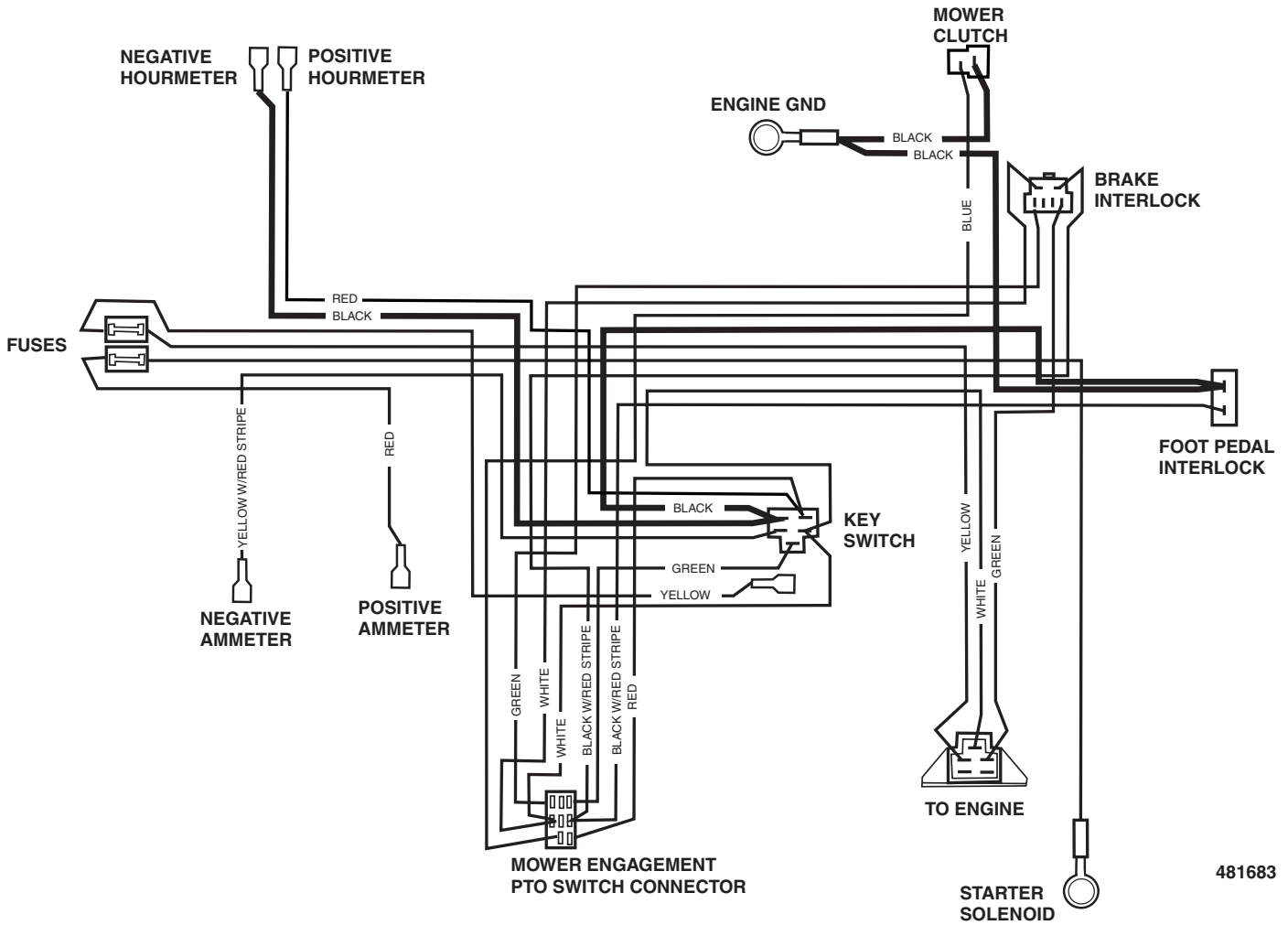

WIRE HARNESS WITH RELAY PART NO. 481275

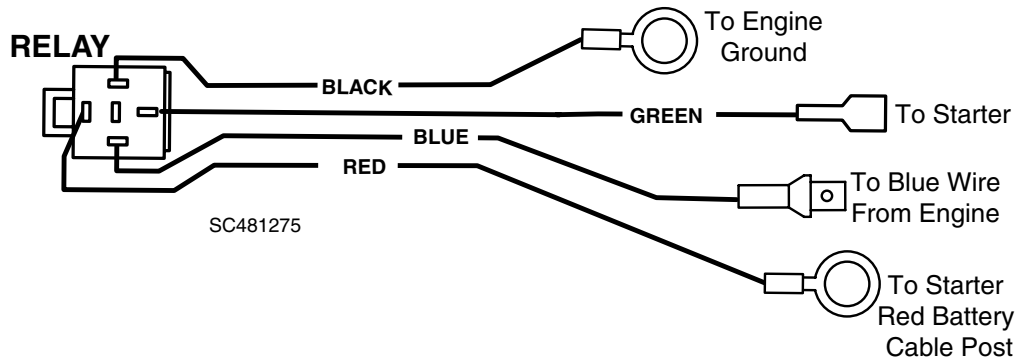

WINCH LIFT SYSTEM

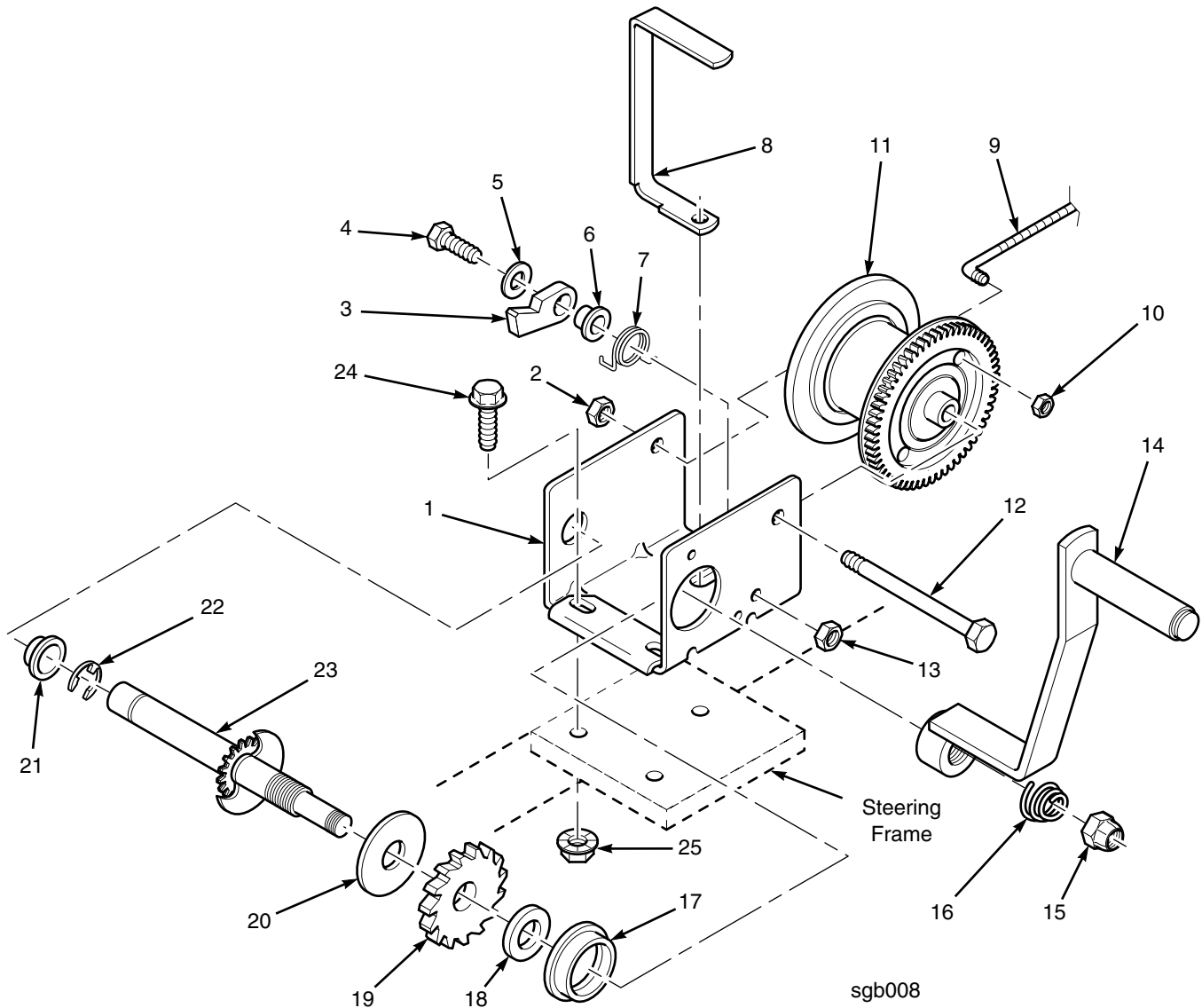

Ref. Part No.	Part Number	Description	Ref. Part No.	Part Number	Description
1	48043	Winch Assembly (Incl. 1-7, 11-13, 15-23)	14	48044	Winch Handle
2	204803	Locknut, 7/16-14	15	205015	Handle Nut
3	404409	Ratchet Pawl	16	204364	Handle Spring
4	205167	Ratchet Bolt	17	208328	Shaft Bushing
5	205055	Flatwasher	18	404163	Pressure Washer
6	404166	Ratchet Spacer	19	404164	Ratchet Wheel
7	204363	Ratchet Spring	20	204362	Pressure Plate
8	42127	Cable Guide	21	204012	Shaft Bushing
9	48045	Winch Cable Assembly	22	205116	E-Ring
10	04021-03	Hex Locknut, 1/4-28	23	304758	Drive Shaft
11	304753	Winch Reel	24	04017-27	Serr. Flg. HH Capscrew, 3/8-16 x 1"
12	203161	Reel Shaft	25	04019-04	Serr. Flg. HH Nut, 3/8-16
13	204803	Hex Locknut, 3/8-16			

REPLACEMENT DECALS & INFORMATION



1



3

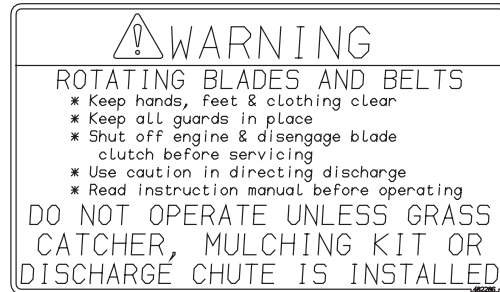

4

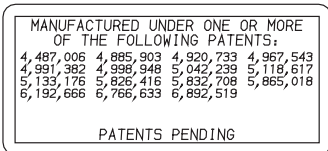

5



9

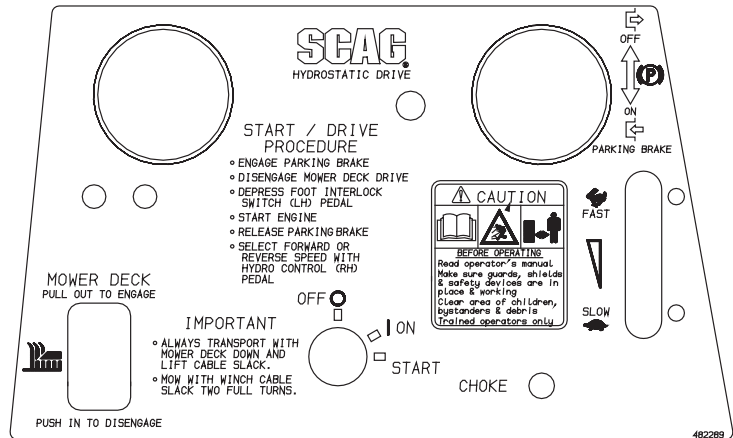

6



7

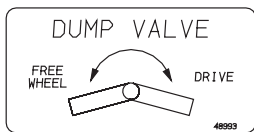

8



482817 CUTTING HEIGHT ADJUSTMENT

DECK MOUNTING HOLE POSITION

NUMBER OF CASTER SPACERS (BELOW SUPPORT)

	NUMBER OF SPACERS ABOVE CUTTER BLADES					
	0	1	2	3	4	5
TOP	2	-	-	-	-	1-5/8
TOP	3	3-1/4	3	2-3/4	2-1/2	2
MIDDLE	4	-	3-3/4	3-1/2	3-1/4	3
BOTTOM	2	-	-	3-3/4	-	-
BOTTOM	3	-	4-1/8	3-7/8	-	-
BOTTOM	4	-	4-3/8	4-1/8	3-7/8	3-5/8
BOTTOM						3-3/8

12

Ref. No.	Part Number	Description	Ref. No.	Part Number	Description
1	481971	Decal, Heavy Duty Commercial	6	482289	Decal, Instrument Panel
2	48314	Decal, Scag Logo (Cutter Deck)	7	481039	Decal, Warning-Belt Cover
2a	48968	Decal, Scag Logo (Battery Box Front)	8	48993	Decal, Dump Valve
2b	48825	Decal, Scag Logo Seat Back	9	48404	Decal, Metalcraft-Made In USA
3	482285	Decal, Danger-Spinning Blades	10	483201	Decal, 61 Velocity Plus
4	482286	Decal, Warning-Rotating Blades	11	481956	Decal, 72 Advantage
5	483044	Decal, Patent	12	482817	Decal, Height of Cut

LIMITED WARRANTY - COMMERCIAL EQUIPMENT

Any part of the Scag commercial mower manufactured by Scag Power Equipment and found, in the reasonable judgment of Scag, to be defective in materials or workmanship, will be repaired or replaced by an Authorized Scag Service Dealer without charge for parts and labor during the periods specified below. This warranty is limited to the original purchaser and is not transferable. Proof of purchase will be required by the dealer to substantiate any warranty claims. All warranty work must be performed by an Authorized Scag Service Dealer.

This warranty is limited to the following specified periods from the date of the original retail purchase for defects in materials or workmanship:

- * Wear items including drive belts, blades, hydraulic hoses and tires are warranted for ninety (90) days.
- * Batteries are covered for ninety (90) days.
- * Frame and structural components including oil reservoir and oil coolers are warranted for 2 years (Parts and labor).
- * Cutter decks are warranted against cracking for a period of three (3) years. (Parts and labor 1st and 2nd year; Parts only 3rd year) The repair or replacement of the cutter deck will be at the option of Scag Power Equipment. We reserve the right to request components for evaluation. This warranty does not cover any mower that has been subject to misuse, neglect, negligence, accident, or that has been operated in any way contrary to the operating instructions as specified in the Operator's Manual.
- * Engines and electric starters are covered by the engine manufacturer's warranty period.
- * Major drive system components are warranted for two (2) years by Scag Power Equipment. (Parts and labor) (Two year warranty exclude fittings, hoses, drive belts). The repair or replacement of the hydraulic pump or hydraulic motor will be at the option of Scag Power Equipment. This warranty does not cover any mower that has been subject to misuse, neglect, negligence, or accident, or that has been operated in any way contrary to the operating instructions as specified in the Operator's Manual.
- * Electric clutches have a Limited Warranty for 2 year (Parts and labor).
- * Cutter Spindle Assemblies have a Limited Warranty for three years (Parts and labor 1st and 2nd year; Parts only 3rd year).
- * Any Scag product used for rental purposes is covered by a 90 day warranty.

The Scag mower, including any defective part must be returned to an Authorized Scag Service Dealer within the warranty period. The expense of delivering the mower to the dealer for warranty work and the expense of returning it to the owner after repair will be paid for by the owner. Scag's responsibility is limited to making the required repairs and no claim of breach of warranty shall be cause for cancellation or rescission of the contract of sale of any Scag mower.

This warranty does not cover any mower that has been subject to misuse, neglect, negligence, accident, or that has been operated in any way contrary to the operating instructions as specified in the Operator's Manual. The warranty does not apply to any damage to the mower that is the result of improper maintenance, or to any mower or parts that have not been assembled or installed as specified in the Operator's Manual and Assembly Manual. The warranty does not cover any mower that has been altered or modified, changing performance or durability. In addition, the warranty does not extend to repairs made necessary by normal wear, or by the use of parts or accessories which, in the reasonable judgment of Scag, are either incompatible with the Scag mower or adversely affect its operation, performance or durability.

Scag Power Equipment reserves the right to change or improve the design of any mower without assuming any obligation to modify any mower previously manufactured. All other implied warranties are limited in duration to the two (2) year warranty period or ninety (90) days for mowers used for rental purpose. Accordingly, any such implied warranties including merchantability, fitness for a particular purpose, or otherwise, are disclaimed in their entirety after the expiration of the appropriate two year or ninety day warranty period. Scag's obligation under this warranty is strictly and exclusively limited to the repair or replacement of defective parts and Scag does not assume or authorize anyone to assume for them any other obligation. Some states do not allow limitations on how long an implied warranty lasts, so the above limitation may not apply to you.

Scag assumes no responsibility for incidental, consequential or other damages including, but not limited to, expense for gasoline, expense of delivering the mower to an Authorized Scag Service Dealer and expense of returning it to the owner, mechanic's travel time, telephone or telegram charges, rental of a like product during the time warranty repairs are being performed, travel, loss or damage to personal property, loss of revenue, loss of use of the mower, loss of time or inconvenience. Some states do not allow the exclusion or limitation of incidental or consequential damages, so the above limitation or exclusion may not apply to you. This warranty gives you specific legal rights, and you may also have other rights which vary from state to state.